

## CVS Series 51 Chemical Injection Pump

---

### Applications

1. The introduction of De-Emulsifiers, corrosion Inhibitors De-scaling Agents, Solvents and Oxygen Scavengers.
2. Water Treatment
3. Methanol Injection in Gas Pipelines.
4. Injection of Surfactant (Soap) into Low Pressure Gas Wells with high water content

---

### Description

The CVS gas driven Series 51 Chemical Injection Pump uses a molded diaphragm to drive a piston through chevron packing making it a positive displacement pump, capable of discharge pressures up to 6000 psig., and maximum volume output up to 30 gallons per day. Unit weight is 22.5 Lbs, shipping weight is 25.5 Lbs

**Traegyr Switch:** The Traegyr Switch is a miniature valve offering reliability with rugged construction. The unit consists of a 3-way, 2 position valve which is positively switched with pilot signal valves. The valve offers positive response, extremely low cycle times lower than one stroke per minute, and the pump half stroke feature is easily used. This valve will not stick in mid-position causing the pump to stall and cannot be vibrated or jarred out of position. (Figure 1)

**Micro Valve:** The Micro Valve unit is a miniature valve offering reliability and rugged construction. With an over center, snap acting operator, the unit consists of a 3-way, 2-position valve. The unit offers sure response, no neutral position, and no varying time lag between positions. Unit maintains either position without holding force, and cannot be vibrated or jarred out of position. (Figure 2)

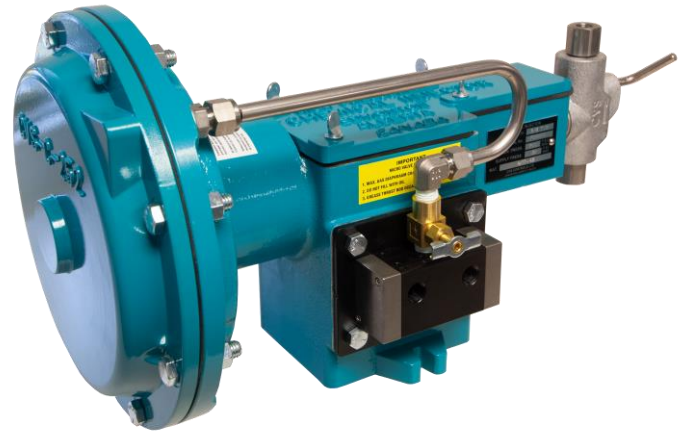

CVS Series 51 Chemical Injection Pump with Traegyr Switch



CVS Series 51 Chemical Injection Pump with Micro Valve

---

### **Description Continued.**

A choice of four plunger sizes, two stroke lengths and controllable strokes per minute (SPM) with an optional slow speed controller allows for a wide range in capacity, from less than 1 quart to 30 gallons/day.

The oil impregnated bronze bushing (not in contact with the gas supply) extends the thrust rod life as well as protects the pump housing.

The standard fluid end is ductile iron with stainless steel trim and plunger; all stainless steel is an available option.

---

### **Installation and Operation**

---

The following components should be shipped loose:

- 1/4" Line Check Valve (One)  
Stainless Steel: CVS-A-0675
  - Packing Gland Wrench (One)  
CVS-A-0315
1. Blow out and remove debris from supply line before hooking up supply air/gas to inlet. Supply pressure should be regulated with a maximum setting of 35 PSI.
  2. Install the furnished Line Check (CVS-A-0675) before the injection point (Note: the direction of the flow arrow). Connect the discharge line to the 1/4" NPT in both the line check and the Top Bushing (CVS-A-1496) of the head assembly. Ensure the line is clear of all foreign debris.
  3. Ensure the Priming Valve (CVS-A-1497) is partially open.
  4. Open the main air/gas supply valve and slowly open the small gas Exhaust Valve (CVS-A-2489). The pump should automatically start. Ensure the suction line is primed with fluid and then test the pump head by opening the Priming Valve. The fluid escaping from the Priming Valve may contain bubbles, as soon as bubbles subside close the Priming Valve for normal operation. Adjust pump for the desired Strokes/Min. and pumping rate. Be sure to keep hands away from moving parts.
  5. Check the Packing Gland for leakage. If leakage is occurring, use the gland wrench supplied to tighten the gland nut until leak just stops. Do not over tighten the Gland Nut. This may stall the pump or generate excessive wear on the packing and/or plunger.
  6. Replace Cover Gasket and Top Cover, secure with Wing Screws.

---

## Maintenance and Troubleshooting

---

- A. Keep the cover in place, and periodically oil the thrust rod.
- B. Regularly check for packing leaks, tighten or replace as required.

**Note:**

**Ensure the plunger packing is not over tightened, as this may score the plunger and decrease the lifespan of the packing.**

- C. CVS chemical pumps used for alcohol or methanol injection must be fitted with Fluoro O-rings. Pumps used for most chemical injection applications should be fitted with Viton O-rings. The O-rings are located in the Top Seat (CVS-B-0737) and Bottom Seat (CVS-B-0736). Refer to manufacturer specifications for elastomer sealing fluid compatibilities.
- D. If the pump fails to stroke and air/gas constantly flows from the Air Vent (CVS-A-1836SS), the diaphragm has ruptured. Disconnect air supply and bleed off pressure. Remove the Diaphragm Cover (CVS-C-0252) and inspect Diaphragm (CVS-C-0290) for rips and tears, replace as required.

**Note:**

**If installing a new diaphragm, shutoff and disconnect air supply and ensure the pressure has been bled off. Remove Lock Nut (CVS-A-3320) and Washer (CVS-A-3321) from the Thrust Rod (CVS-B-0444). To prevent the thrust rod from turning, remove the Top Cover (CVS-B-0548) and insert a punch or drift pin into the large hole forward of the Trip Assembly (CVS-MV-003). At this point, visually inspect the Return Spring (CVS-A-1821) for damage.**

- E. If no air/gas venting, check the supply pressure (35 PSI Max). Erratic changes in pressure may cause the pump to stall.

- F. If pump stalls in the forward discharge position, shut off the air/gas supply. Check if the packing gland nut is over tightened. Readjust packing as required.
- G. If the pump is running, but not pumping, the injection head could be air locked. Open the priming valve and bleed fluid until no bubbles are present. If still not pumping, the O-ring in the bottom seat may have failed and needs replacing.
- H. If micro valve needs replacement, shutoff air/gas supply ensuring all pressure is bled off. Disconnect supply and output tubing. Remove the Hex Head Machine Screws (CVS-A-0141) that secure the micro valve plate to pump body. Remove the Micro Valve Switch (CVS-MV-004) with plate (CVS-MV-014) and separate. Mount a new micro valve switch to micro valve plate and secure assembly to body. Ensure the micro valve extension is centered between both trip arms on trip bar assembly.

## Maintenance and Troubleshooting cont'd

- I. If Traegy Switch requires replacement, shut off air/gas supply. Make sure all air/gas has been bled off. Disconnect supply and output tubing. Remove the hex head machine screws (CVS-A-0141) that secure the Traegy valve plate to the pump body. Remove rocker arm first, then remove the machines screws that attach the Traegy plate to the Traegy Switch.

Mount a new Traegy switch to the plate and rocker arm, then secure assembly to body. Ensure the trip arm is located at the home position (located closest to diaphragm side) see diagram below. Orient the trip bar so the rocker arm is rotated toward the diaphragm side ensuring the bearing of the pilot valve is depressed. Tighten the setscrew on trip bar assembly to lock rocker arm in place. Open the exhaust valve slowly, this will send a signal to the pilot valve and set the trip bar and rocker arm in motion toward the adjacent pilot valve bearing (this puts the switch in a balanced state).

If system pressure is temporarily lost, the trip arm will return to home position BUT because the switch is balanced, when system pressure is restored the trip assembly will be set in motion.

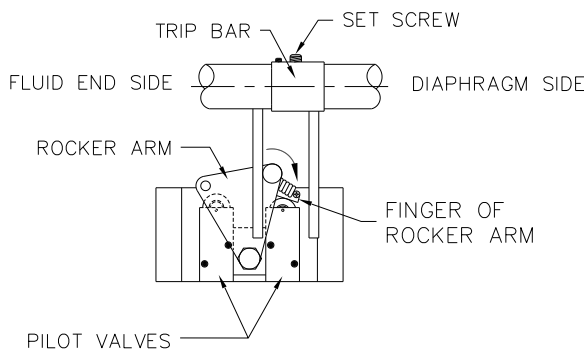

ENSURE ROCKER ARM IS ROTATED TO THE DIAPHRAGM SIDE.  
 -SLIDE TRIP BAR INTO PLACE  
 -FINGER OF ROCKER ARM MUST DEPRESS BEARING  
 -TIGHTEN SET SCREW

HOME POSITION  
 TRAEGY VALVE  
 SET UP

## Start Up

1. a) If Traegy Valve operated, lightly grease thrust rod.  
 b) If Micro Valve operated, lightly grease thrust rod.
2. Ensure all piping and tubing have been properly connected.
3. Determine the number of strokes/min. required to achieve desired injection flowrate (See Technical Data).
4. Open air/gas supply to start unit and adjust to desired strokes/min.
5. Crack open the Priming Valve to ensure pump action and that unit is not airlocked.
  - a) If Traegy Switch does not respond after checking for arilock, you may have to press the pilot bearing located at the home position to initiate the valve (see step J).
6. Inspect packing and connections for leakage.
7. Once unit is left in continuous operation periodically lubricate and check packing and connections for leakage.



**Figure 4: Traegy Switching Relay Home Position**

## CVS Series 51 Chemical Injection Pump with Traegyr Valve

### Parts List

Item	Part Number	Qty	Name	Material	Item	Part Number	Qty	Name	Material
1	CVS-C-0252	1	Diaphragm Cover	Aluminum	21	CVS-MV-001	1	Trip Arm	Steel/Cad.
2	CVS-D-0251	1	Housing	Aluminum	22	CVS-MV-002	1	Trip Bar	Steel/Cad.
*3	CVS-C-0290	1	Diaphragm	Cotton/Nitrile	23	CVS-MV-003	1	Trip Assembly.	Steel/Cad.
	CVS-C-0290/HS	1	Diaphragm	Highly Saturated		24	CVS-C-0275	1	1/4" Injector Head
4	CVS-A-3321	1	Washer	Hvy Stl Cad Pl		CVS-C-0276	1	3/8" Injector Head	Cast Stl Pl
*5	CVS-A-3320	1	Locknut	Stl. Cad. Pl.	**25	CVS-A-0315	1	Gland Wrench	Steel
7	CVS-A-0136	4	Wing Screws	Stl. Cad. Pl.	*27	CVS-A-1828	1	Adjusting Pin	Steel
8	CVS-B-0438	1	Diaphragm Plate	Steel	28	CVS-A-1546	1	Cover Gasket	Buna-N
9	CVS-B-0548	1	Cover	Aluminum	29	CVS-B-0001	1	Bushing	Bronze
	CVS-B-0548/CL	1	Cover	Clear Acrylic					
10	CVS-B-0444	1	Thrust Rod	Steel	*30	CVS-TV-051010	1	Pneumatic Switching relay	—
11	CVS-TV-014	1	Traegyr Switch Plate	Steel	34	CVS-A-0225	1	Injector head Locknut	Brass
12	CVS-MV-012	1	Set Screw	Steel	35 <sup>A</sup>	CVS-TV-KIT	1	Traegyr Valve Kit	Std./Dry Sour
13	CVS-B-0447	1	Rod Adapter	Steel/Cad Pl.					
*14	CVS-A-0290	1	Pin	Steel					
15	CVS-A-0139	8	Hex Hd. CapScrew	Steel/Cad Pl.					
16	CVS-A-2207	8	Hex Nut	Steel/Cad Pl.					
17	CVS-A-0141	4	Base Screw	C.S. Cad. Pl.					
19	CVS-MV-013	1	Set Screw	Steel					
20	CVS-A-1835SS	1	Air Vent	SST					

- \* Recommended Spare Parts
- \*\* Parts not mounted, packaged with unit

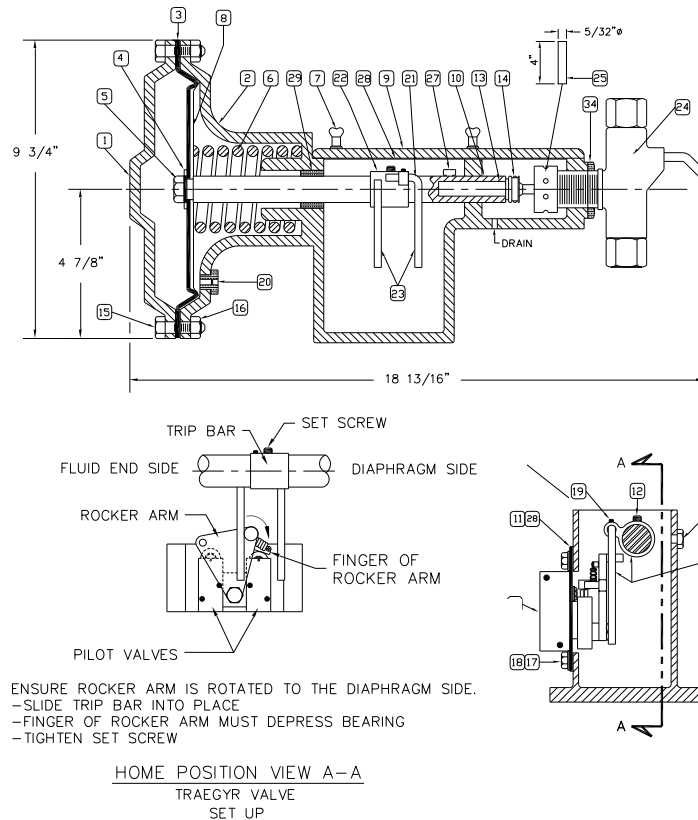

Figure 5: CVS Series 51 Chemical injection Pump with Traegyr Valve

## CVS Series 51 Chemical Injection Pump with Traegyr Valve

Item	Part Number	Qty	Name	Material
30	CVS-TV-051010	1	Pneumatic Switching Relay	-----
31	3/8" Tubing	1	3/8" Tubing	SST
32		1	Male Elbow 3/8 Tube x 1/4 Male NPT	SST
33	CVS-A-2489	1	Exhaust Valve	Pl. Brass
34	CVS-A-0225	1	Injector Head locknut	Brass
35		1	Male Elbow 3/8 Tube x 1/4 Male NPT	

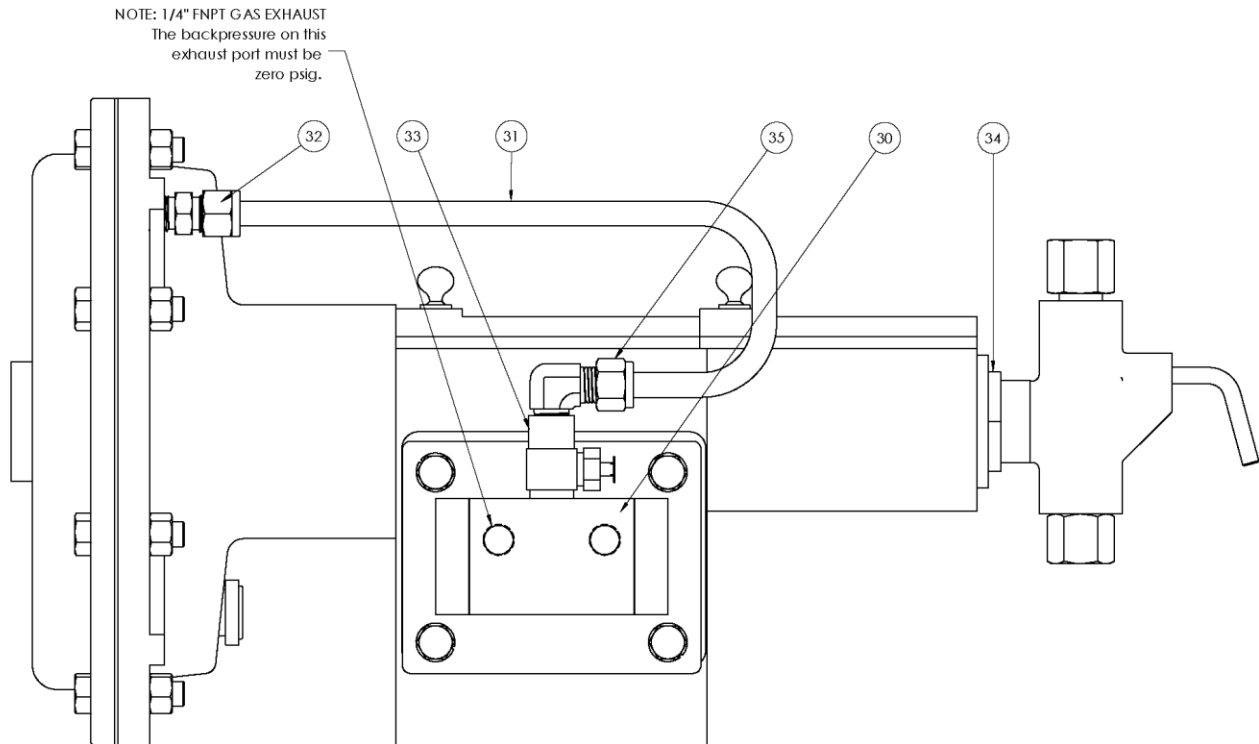

Figure 6: CVS Series 51 Chemical injection Pump with Traegyr Switch

## CVS Series 51 Chemical Injection Pump with Micro Valve

### Parts List

Item	Part Number	Qty	Name	Material	Item	Part Number	Qty	Name	Material
1	CVS-C-0252	1	Diaphragm Cover	Aluminum	21	CVS-MV-001	1	Trip Arm	Steel/Cad.
2	CVS-D-0251	1	Housing	Aluminum	22	CVS-MV-002	1	Trip Bar	Steel/Cad.
*3	CVS-C-0290	1	Diaphragm	Buna-N	23	CVS-MV-003	1	Trip Assembly.	Steel/Cad.
	CVS-C-0290/HS	1	Diaphragm	Highly Saturated	24	CVS-C-0275	1	1/4" Injector Head	Cast Stl Pl
4	CVS-A-3321	1	Washer	Hvy Stl Cad Pl		CVS-C-0276	1	3/8" Injector Head	Cast Stl Pl
*5	CVS-A-3320	1	Locknut	Stl. Cad. Pl.		**25	CVS-A-0315	1	1/2" Injector Head
*6	CVS-A-1821	1	Return Spring	CS Cad. Pl.					
	CVS-A-1821SS			SST					
7	CVS-A-0136	4	Wing Screws	Stl. Cad. Pl.	*28	CVS-A-1828	1	Gland Wrench	Steel
8	CVS-B-0438	1	Diaphragm Plate	Steel	29	CVS-A-1546	1	Adjusting Pin	Steel
9	CVS-B-0548	1	Cover	Aluminum	30	CVS-B-0001	1	Cover Gasket	Buna-N
10	CVS-B-0444	1	Thrust Rod	Steel	*31	CVS-MV-004	1	Bushing	Bronze
11	CVS-MV-014	1	Micro Valve Plate	Steel	38	CVS-A-0225	1	Micro Switch	—
12	CVS-MV-012	1	Set Screw	Steel	39 <sup>A</sup>	CVS-MV-KIT	1	Injector head Locknut	Brass
13	CVS-B-0447	1	Rod Adapter	Steel/Cad Pl.				Micro Valve Conversion Kit	Std.
*14	CVS-A-0290	1	Pin	Steel					
15	CVS-A-0139	8	Hex Hd. CapScrew	Steel/Cad Pl.					
16	CVS-A-2207	8	Hex Nut	Steel/Cad Pl.					
17	CVS-A-0141	4	Base Screw	C.S. Cad. Pl.					
19	CVS-MV-013	1	Set Screw	Steel					
20	CVS-A-1835SS	1	Air Vent	SST					

• A Not Shown  
 • \* Recommended spare parts.  
 • \*\* Parts not mounted, packaged with unit.

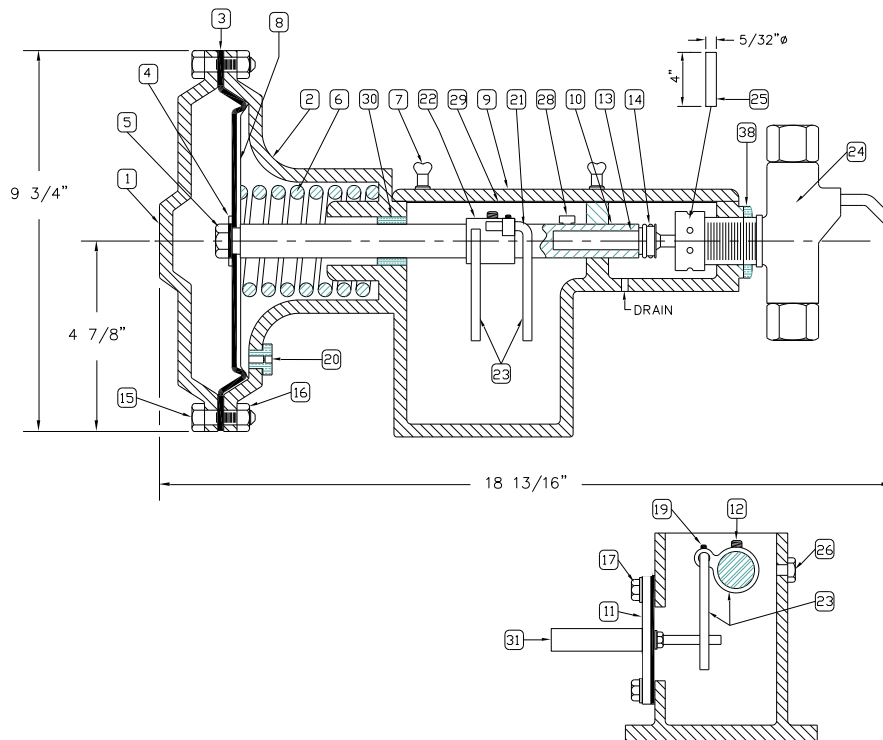

### CVS Series 51 Chemical Injection Pump with Micro Valve

Item	Part Number	Qty	Name	Material
32	CVS-A-1193	1	3/8" Tubing	SST
33		1	Male Connector 3/8 Tube x 1/4 Male NPT	SST
34	CVS-A-2489	1	Exhaust Valve	Pl. Brass
35	CVS-A-0075	1	Street Elbow	C.S.
36	CVS-MV-007	3	Reducers	Pl. Brass
37	CVS-A-0225	1	Injector Head Locknut	Brass </td
38		1	Male Elbow - 3/8 Tube x 1/4 Male NPT	SST

NOTE: 1/4" FNPT GAS EXHAUST  
 The backpressure on this  
 exhaust port must be  
 zero psig.

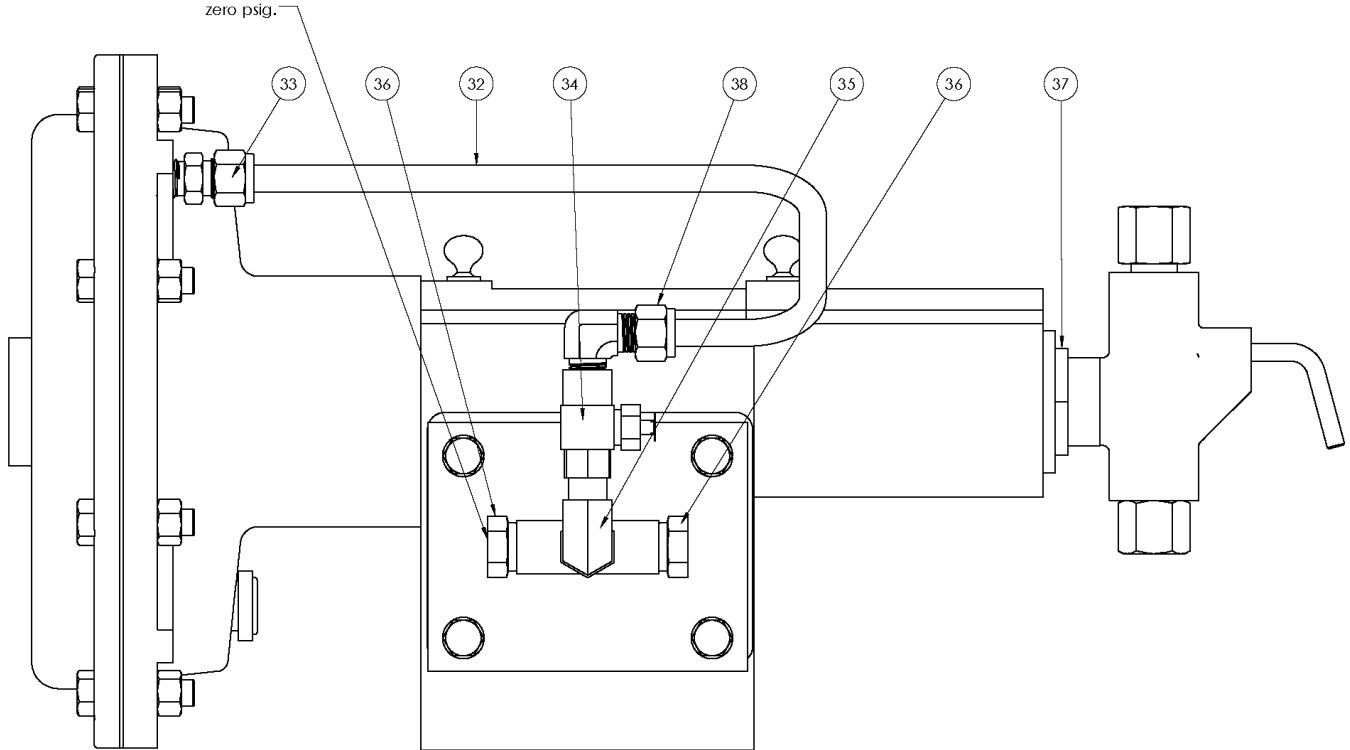

Figure 8: CVS Series 51 Chemical injection Pump with Micro Valve



## Check Valve for CVS Series 51 Chemical Injection Pump

### Parts List

Item	Part Number	Qty	Name	Material
12*	CVS-A-0391	1	Spring	SST
13*	CVS-A-0054	1	3/8" Ball	SST
14*	CVS-A-0479/FS	1	O-Ring	Flourosilicone
	CVS-A-2580	1		Viton
	CVS-A-0479	1		Buna-N
16	CVS-A-1296	1	Outlet Body	SST
17	CVS-A-1297	1	Inlet Body	SST
18*	CVS-A-1574	1	Washer	Soft Iron

\* Recommended spare parts.

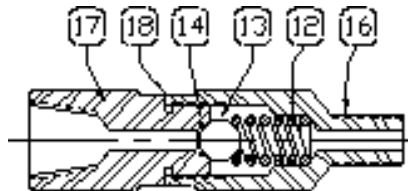

**CVS-A-0675**  
**303 SS LINE CHECK**

# Injector Heads for CVS Series 51 Chemical Injection Pump

## Parts List

Pump Model Numbers →			51-316			51-14 Soft Packing		51-38 Soft Packing		51-12 Soft Packing	
ITEM	DESCRIPTION	MAT'L	ALL SST TRIM	DUCTILE W/S.S. TRIM	ALL SST TRIM	DUCTILE W/S.S. TRIM	ALL SST TRIM	DUCTILE W/S.S. TRIM	ALL SST TRIM	DUCTILE W/S.S. TRIM	ALL SST TRIM
	HEAD ASSY. NO.		CVS-B-1472	CVS-B-0166	CVS-B-0755	CVS-B-0203	CVS-B-0756	CVS-B-0496	CVS-B-0732		
1	Body		CVS-C-2040	CVS-C-0275	CVS-C-0291	CVS-C-0276	CVS-C-0425	CVS-C-0272	CVS-C-0349		
2*	Plunger	17-4PH	CVS-A-5643	CVS-A-1312	CVS-A-1312	CVS-A-1745	CVS-A-1745	CVS-A-1876	CVS-A-1876		
	Plunger, Cryo-Treated					CVS-A-1745/CT	CVS-A-1745/CT				
3	Plunger Packing Gland	303 SST	CVS-A-5642	CVS-A-1463	CVS-A-1463	CVS-A-0957	CVS-A-0957	CVS-A-1219	CVS-A-1219		
4*	Plunger Packing** (See table for max. discharge press.)	Buna-N Hard Viton Teflon Flourosilicone	CVS-A-3969 CVS-A-3948 CVS-A-3967 CVS-A-3966 CVS-A-3969/FS	CVS-A-1461 CVS-A-2295 CVS-A-4102 CVS-A-1642 CVS-A-1461/FS	CVS-A-1461 CVS-A-2295 CVS-A-4102 CVS-A-1642 CVS-A-1461/FS	CVS-A-1456 CVS-A-1875 CVS-A-4101 CVS-A-1234 CVS-A-1456/FS	CVS-A-1456 CVS-A-1875 CVS-A-4101 CVS-A-1234 CVS-A-1456/FS	CVS-A-0959 CVS-A-1874 CVS-A-4103 CVS-A-1012 CVS-A-0959/FS	CVS-A-0959 CVS-A-1874 CVS-A-4103 CVS-A-1012 CVS-A-0959/FS		
5*	O-Ring, Suction & discharge (included in items 9 & 14)	Buna-N Viton Flourosilicone	CVS-A-0479 CVS-A-2580 CVS-A-0479/FS	CVS-A-0479 CVS-A-2580 CVS-A-0479/FS	CVS-A-0479 CVS-A-2580 CVS-A-0479/FS	CVS-A-0479 CVS-A-2580 CVS-A-0479/FS	CVS-A-0479 CVS-A-2580 CVS-A-0479/FS	CVS-A-0479 CVS-A-2580 CVS-A-0479/FS	CVS-A-0479 CVS-A-2580 CVS-A-0479/FS	CVS-A-0479 CVS-A-2580 CVS-A-0479/FS	CVS-A-0479 CVS-A-2580 CVS-A-0479/FS
6	Top Bushing	302 SST	CVS-A-1496-1	CVS-A-1496	CVS-A-1496	CVS-A-1496	CVS-A-1496	CVS-A-1496	CVS-A-1496		
7*	Spring	316 SST	CVS-A-0077	CVS-A-0077	CVS-A-0077	CVS-A-0077	CVS-A-0077	CVS-A-0077	CVS-A-0077		
8*	3/8" SST Ball	316 SST	CVS-A-0054	CVS-A-0054	CVS-A-0054	CVS-A-0054	CVS-A-0054	CVS-A-0054	CVS-A-0054		
9*	Top Seat Assy	303 SST	CVS-B-0737	CVS-B-0737	CVS-B-0737	CVS-B-0737	CVS-B-0737	CVS-B-0737	CVS-B-0737		
	Top Seat Assy (Metal to Metal)		-----	CVS-A-0806	CVS-A-0806	CVS-A-0806	CVS-A-0806	CVS-A-0806	CVS-A-0806	CVS-A-0806	
10*	1/4" SST Ball	316 SST	-----	CVS-A-0126	CVS-A-0126	CVS-A-0126	CVS-A-0126	CVS-A-0126	CVS-A-0126		
11	Priming Valve	303 SST	CVS-A-5462	CVS-A-1497	CVS-A-1497	CVS-A-1497	CVS-A-1497	CVS-A-1497	CVS-A-1497		
12	Plunger Pkg. Gland Nut	303 SST	CVS-A-4104	CVS-A-4104	CVS-A-4104	CVS-A-4104	CVS-A-4104	CVS-A-4104	CVS-A-4104		
13*	Suction Ball - 3/8"	316 SST	CVS-A-0054	CVS-A-0054	CVS-A-0054	CVS-A-0054	CVS-A-0054	CVS-A-0054	CVS-A-0054		
	Suction Ball - 1/2" (use with CVS-A-0771 metal to metal bottom seat only)		-----	CVS-A-0053	CVS-A-0053	CVS-A-0053	CVS-A-0053	CVS-A-0053	CVS-A-0053	CVS-A-0053	
14*	Bottom Seat	303 SST	CVS-B-1216	CVS-B-0736	CVS-B-0736	CVS-B-0736	CVS-B-0736	CVS-B-0736	CVS-B-0736		
	Bottom Seat Metal to Metal (use with CVS-A-0053 1/2" ball only)		-----	CVS-A-0771	CVS-A-0771	CVS-A-0771	CVS-A-0771	CVS-A-0771	CVS-A-0771	CVS-A-0771	
15	Locknut	Brass	CVS-A-0225	CVS-A-0225	CVS-A-0225	CVS-A-0225	CVS-A-0225	CVS-A-0225	CVS-A-0225		
16	Gasket	304 SST	CVS-A-4394	-----	-----	-----	-----	-----	-----		

\* Recommended Spare Parts

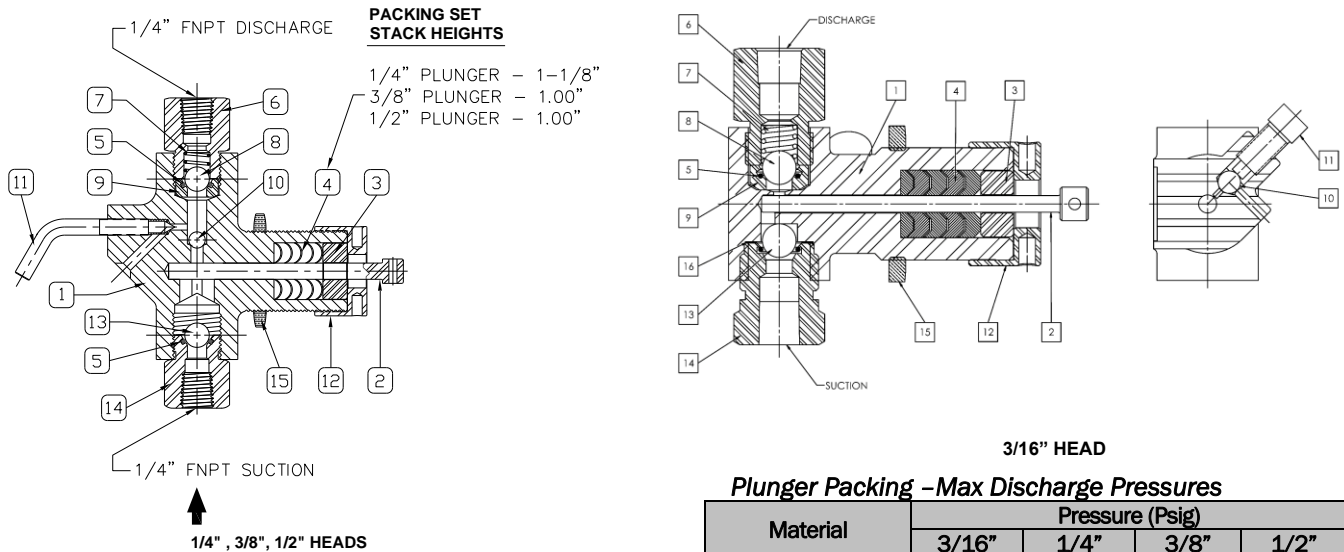

Figure 12: Injector Heads for CVS Series 51 Chemical Injection Pump

**3/16" HEAD**

**Plunger Packing - Max Discharge Pressures**

Material	Pressure (Psig)			
	3/16"	1/4"	3/8"	1/2"
Buna-N	5000	1500	1500	1500
Hard	6000	6000	6000	3500
Viton	5000	3500	3500	3500
Teflon	3000	1500	1500	1500
Flouro	1500	1500	1500	1500

Please contact a CVS Controls Sales Representative for other seal and plunger material options

## CVS Series 51 Chemical Injection Pump, Conversion from Pilot Valve to Micro Valve

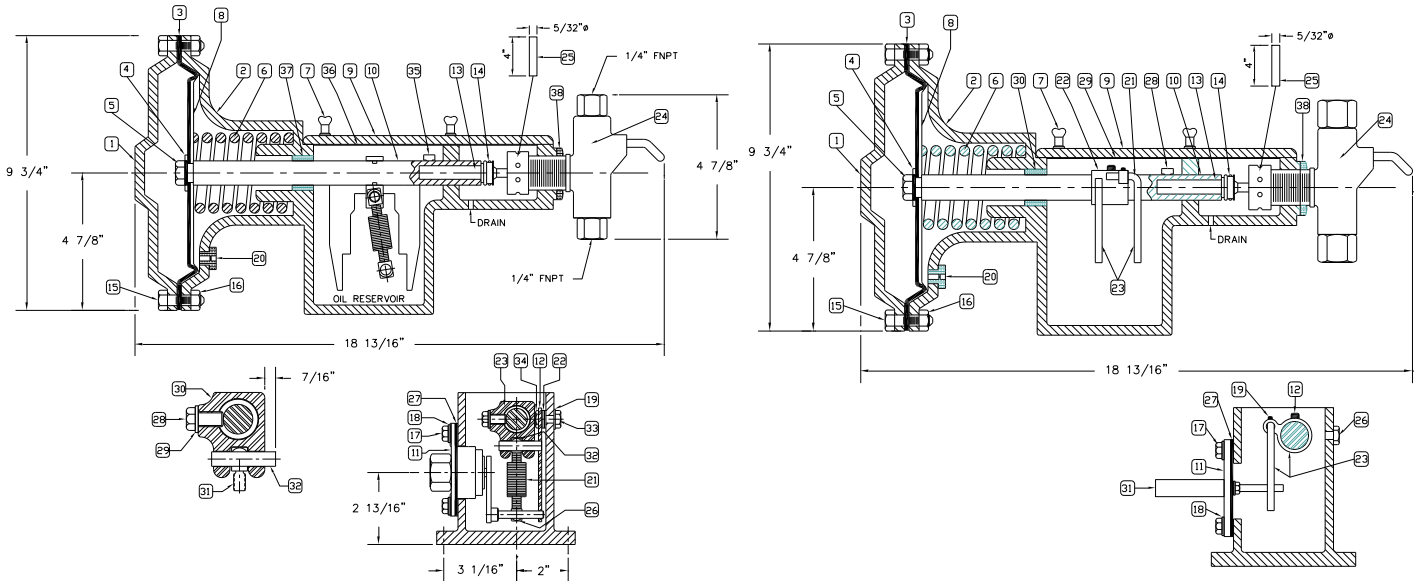

Pilot Valve

Micro Valve

### Micro Valve Conversion Kit

Check for the following shipped components:

- (One) 3/8" SS Tubing, CVS-A-1193
- (One) Trip Assembly, CVS-MV-003  
Consists of: Trip Arm, CVS-MV-001 (One); Trip Bar, CVS-MV-002 (One); Set Screw CVS-MV-013 (One) and Set Screw; CVS-MV-012 (One)
- (One) Male Connector, CVS-A-4015
- (One) Micro Switch Assembly
- (One) Male Elbow, CVS-MV-006  
Consists of: Micro Switch, CVS-MV-004 (One); Micro Valve Plate, CVS-MV-014 (One); Reducers, CVS-MV-007 (Three); Street Elbow, CVS-A-0075 (One) and Needle Valve, CVS-A-2489 (One)

### To convert from Pilot Valve to Micro Valve follow the instructions listed below:

1. Disconnect air/gas supply to pilot and discharge line from head
2. Remove pilot valve assembly (Item, # 11)
3. Remove adjusting pin (Item, #35)
4. Loosen Stirrup Assembly (Item #23)
5. Remove diaphragm cover (Item, #1)
6. Slide out diaphragm and thrust rod assembly (Consists of Items # 3, 4, 5, 8 and 10)
7. Remove stirrup assembly (Item, #23)
8. Remove bumper plate (Item, #12)
9. Install Micro Valve trip bar <sup>c/w</sup> trip arm (Item, # 23)
10. Re-install diaphragm and thrust rod assembly (Consists of Items # 3, 4, 5, 8 and 10)
11. Re-install diaphragm cover (Item, #1)
12. Tighten set screw on trip bar (Item, #12)
13. Install micro-valve assembly
14. Install fittings and tubing
15. Reconnect discharge line and air supply
16. Re-install adjusting pin (Item, #28)

## CVS Series 51 Chemical Injection Pump, Conversion from Pilot Valve to Traegy Switch

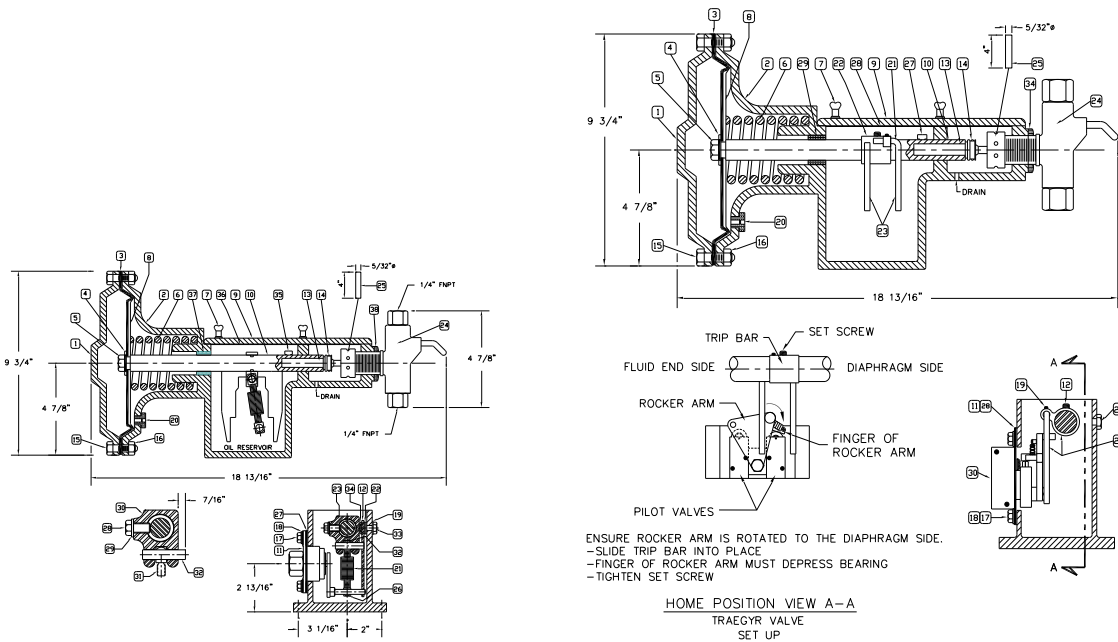

### Traegy Valve Conversion Kit

Check for the following shipped components:

- (One) 3/8" SS Tubing
- (One) Trip Assembly, CVS-MV-003  
Consists of: Trip Arm, CVS-MV-001 (One); Trip Bar, CVS-MV-002 (One); Set Screw CVS-MV-013 (One)  
Set Screw; CVS-MV-012 (One)
- (One) Male Tubing Connector, CVS-A-4015
- (One) Traegy Switch Relay  
Consists of: (one) Switch Relay, CVS-TV-051010, (One) Traegy Valve Plate, CVS-TV-014  
(one) Needle Valve, CVS-A-2489

**\*\*\*IMPORTANT\*\*\***

During setup ensure the trip arm is located at the home position (located closest to the diaphragm side) see above diagram. Make sure the gas/air supply exhaust valve is closed. Note: When switch is new it is unbalanced. Orient the trip bar arm so the rocker arm is rotated to the diaphragm side ensuring the bearing on the pilot valve is fully depressed. Tighten the set screw on the trip bar assembly. Open the exhaust valve slowly, this will send a signal and set arm in motion toward adjacent pilot valve bearing (this puts the switch in a balanced state). If system pressure is temporarily lost, the trip arm will return to the home position. When system pressure is restored the trip arm will be set in motion.

**To convert from Pilot Valve to Traegy Valve follow the instructions listed below:**

- |   |  |
|---|--|
| <ol style="list-style-type: none"> <li>1 Disconnect air/gas supply to pilot and discharge line from head</li> <li>2 Remove pilot valve assembly (Item, # 11)</li> <li>3 Remove adjusting pin (Item, #35)</li> <li>4 Loosen Stirrup Assembly (Item #23)</li> <li>5 Remove diaphragm cover (Item, #1)</li> <li>6 Slide out diaphragm and thrust rod assembly</li> <li>7 Remove stirrup assembly (Item, #23)</li> <li>8 Remove bumper plate (Item, #12)</li> </ol> | <ol style="list-style-type: none"> <li>9 Install Trip Bar Assembly</li> <li>10 Re-install diaphragm and thrust rod assembly (Consists of Items # 3, 4, 5, 8 and 10)</li> <li>11 Re-install diaphragm cover (Item, #1)</li> <li>12 Tighten set screw on trip bar (Item, #12)</li> <li>13 Install Traegy switch assembly (#17), see note above</li> <li>14 Install fittings and tubing</li> <li>15 Reconnect discharge line and air supply</li> <li>16 Re-install adjusting pin (Item, #28)</li> </ol> |
|---|--|

## CVS Series 51 Chemical Injection Pump, Technical Data

Model No.* Standard Packing <sup>1</sup>	Plunger Size (Inches)	Max. Discharge Pressure (Psig)	Max. Volume (GPD)	Operation Ratio Fluid/Gas
CVS-51-316	3/16"	1500	4.2	1200/1
CVS-51-14	1/4"	1500	7.5	750/1
CVS-51-38	3/8"	1500	16.8	300/1
CVS-51-12	1/2"	1500	30.0	180/1
HARD PACKING <sup>2</sup>	Plunger Size	Max Discharge (psig)	Max Volume (GPD)	
CVS-51-316	3/16"	6000	2.8	1200/1
CVS-51-14	1/4"	6000	5.0	750/1
CVS-51-38	3/8"	6000	12.0	300/1
CVS-51-12	1/2"	3500	22.0	180/1

\*Specify Traegyr Switch, Micro Valve, or Pilot Valve, followed by required packing for application.

1 - Volumes shown for low pressure heads with standard packing are at zero psig discharge pressure

2 - Volumes shown for high pressure heads with hard packing are shown at 1500 psig discharge pressure

### Maximum Recommended Speed Above 1500 psig Injection Pressure

3/16" Plunger - 28 Strokes Per Minute

1/4" Plunger - 26 Strokes Per Minute

3/8" Plunger - 14 Strokes Per Minute

1/2" Plunger - 14 Strokes Per Minute

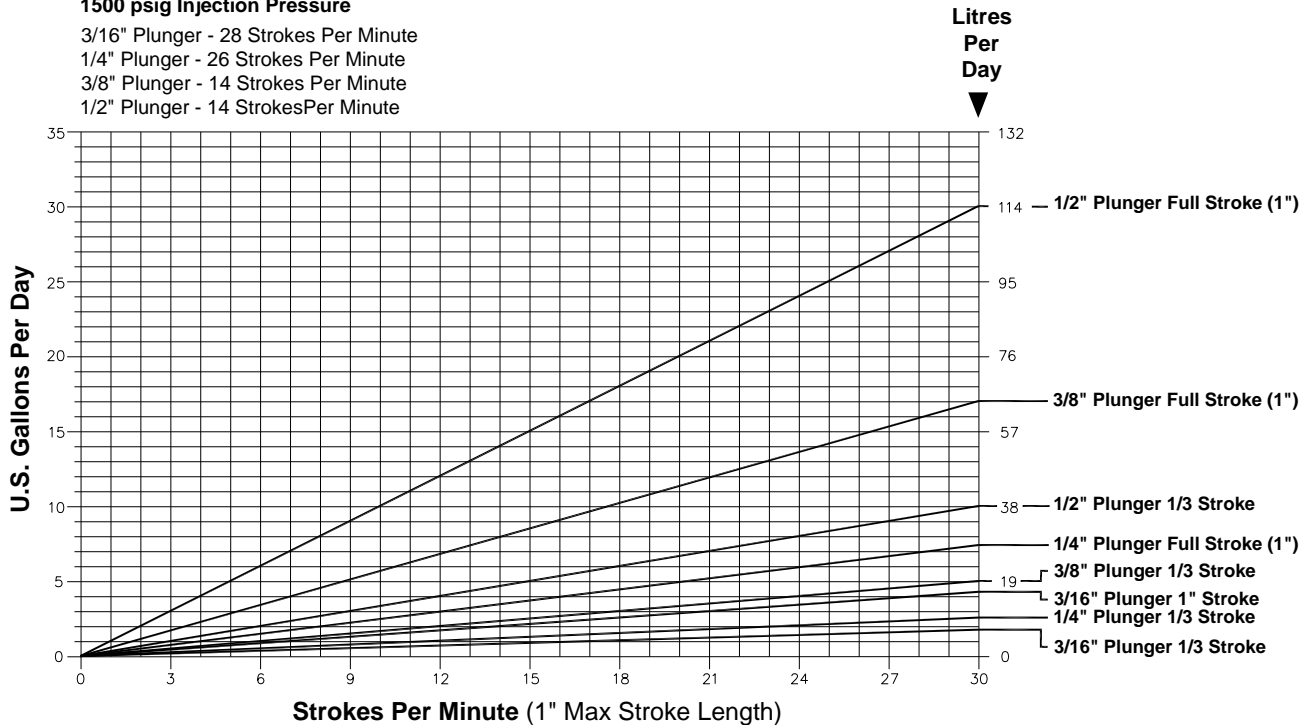

<b>Estimated Gas Consumption (Standard cubic feet of gas required to pump one U.S. gallon) For Inlet regulator sizing, double the requirement indicated.</b>												
Injection Press. In PSIG		100	200	500	1000	1500	2000	3000	3500	4000	5000	6000
3/16" Plunger	1" Stroke	457	458	462	470	475	530	545	555	560	575	589
	1/3" Stroke	1371	1374	1386	1407	1428	1590	1635	1665	1680	1725	1776
1/4" Plunger	1" Stroke	244	245	248	270	288	308	340	355	369	405	497
	1/3" Stroke	732	735	744	810	864	924	1020	1065	1107	1215	1491
3/8" Plunger	1" Stroke	120	126	148	164	177	185	243	278	314	355	374
	1/3" Stroke	360	378	444	492	531	555	729	834	942	1065	1122
1/2" Plunger	1" Stroke	53	54	57	62	71	76	84	95	----	----	----
	1/3" Stroke	159	162	171	186	213	228	252	285			

Notes:

Notes:



Website: [www.cvs-controls.com](http://www.cvs-controls.com) E-Mail: [info@cvs-controls.com](mailto:info@cvs-controls.com)

**Head Office**

1107 8a Street  
Nisku, Alberta, Canada  
T9E 7R3  
Office: (780) 437-3055

**Calgary Sales Office**

3516 114 Avenue SE  
Calgary, Alberta,  
Canada T2Z 3V6  
Office: (403) 250-1416  
Fax: (403) 291-9487

CVS Controls Ltd. strives for the highest levels of quality and accuracy. The information included in this publication is presented for informational purposes only. CVS Controls Ltd. reserves the right to modify or change, and improve design, process, and specifications without written notice. Under no circumstance is the information contained to be interpreted to be a guarantee/warranty with regard to our products or services, applicability or use. Selection, use and maintenance are the sole responsibility of the end user and purchaser. CVS Controls assumes no liability for the selection use and maintenance of any product.

January 2025