

CVS Controls Ltd Electric Chemical Pump

The CVS Controls Electric Chemical pump is an energy efficient and environmentally smart alternative solution for todays demanding chemical injection applications.

Applications:

1. Designed for the introduction of demulsifiers, corrosion inhibitors, de-scaling agents, solvents and oxygen scavengers.
2. Water treatment
3. Methanol Injection in gas pipelines
4. Injection of surfactant (soap) into low pressure gas wells with high water content

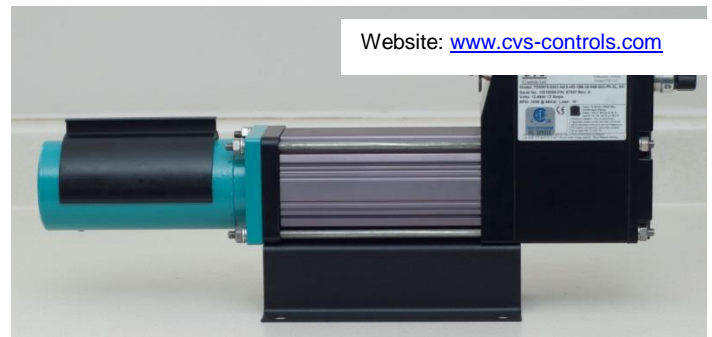

Innovative:

CVS Controls has developed an AC and DC powered servo drive electric chemical pump. The linear servo drive actuator forces a plunger through several options of packing with discharge pressures up to 6000 psi. Available in 110 – 240 Vac 50/60 Hz and 12- 24 Vdc.

CSA approved Class 1, Div 2, Group A, B, C and D T4 temperature rating - 40°C to 65°C with ingress protection of IP65. Additional certifications include CE.

Pump rate is controlled by a speed control dial which controls the pump from 0 strokes per minute to its maximum 60 strokes per minute. The electric pumps are capable of discharge pressures up to 6000 psi while maintaining 60 strokes per minute (40 strokes per minute for 12Vdc model only.)

Quick Start Guide – CVS Controls AC Electric Servo Pump

Input Voltage (DC models): 12 - 24 Vdc, 1 18 Amps max		
Drive Model	Drive Description	Input Continuous Current (A rms)
TDM075	75mm linear actuator	13

- Use 12 AWG wire for input power and PE (ground) connections using approved conductors only.
- External means of approved power disconnect (switch) must be used prior to the pump AC input connections supplied by the customer.
- **Ensure speed control dial on the back of the pump is turned fully counterclockwise before turning on the main power disconnect. This will ensure the pump does not start when the power is initially turned on.**

Power Connections on Terminal board DC Electric Pump

Signal	Terminal Label	Minimum Wire AWG.
Bus Power (+) 12-48 V dc	Bus +	12
Power Common (-)	COMMON	12
Logic Power (+) 12-48 V dc	LOGIC +	18
PE (GND)	PE	12



1. Turn on main power disconnect. The pump will retract and go to the home position. Slowly turn the speed control clockwise until your desired pump strokes per minute is obtained. The pump flow rate is calculated using a standard rate gauge as used with pneumatic pumps. Turning the speed control 270° clockwise will give the maximum pump speed.
2. In the event the pump stops simply turn off the main power disconnect for 30 seconds, then turn the power on. The pump will automatically clear the faults return to its home position and begin pumping again. If it faults again please contact your CVS Controls representative.

Safety Considerations

Warnings and Cautions

As with any electro-mechanical device, safety must be considered during the installation and operation of your CVS Controls Electric Servo Pump. Throughout this manual you will see paragraphs marked with CAUTION and WARNING signs as shown below:

WARNING



“WARNING” indicates the information following is essential to avoiding a safety hazard.

CAUTION



“CAUTION” indicates the information following is necessary for avoiding a risk of damage to the product or other equipment.

WARNING

General



Failure to follow safe installation guidelines can cause death or serious injury. The voltages used in the product can cause severe electric shock and/or burns and could be lethal. Extreme care is necessary at all times when working with or adjacent to the product. The installation must comply with all relevant safety legislation in the country of use. The forces created by actuator could be lethal or cause severe injury if proper protection is not provided to keep personnel away from moving components.

WARNING

System Design and safety for personnel



The actuator is intended as a component for professional incorporation into complete equipment or a system. If installed incorrectly, the actuator may present a safety hazard. The actuator uses high voltages and currents, carries a high level of stored electrical energy, and is used to control equipment which can cause injury. Close attention is required to the electrical installation and the system design to avoid hazards either in normal operation or in the event of equipment malfunction. System design, installation, commissioning and maintenance must be carried out by personnel who have the necessary training and experience. They must read this safety information and this manual carefully.

None of the functions or features of the CVS Controls Electric Servo Pump may be used to ensure safety of personnel, i.e. they must not be used for safety-related functions.

For example the actuators enable / disable, brake, stop/start and forward/reverse functions are not sufficient for use in safety-critical applications without additional independent channels of protection. Careful consideration must be given to the functions of the actuator which might result in a hazard, either through their intended behavior or through incorrect operation due to a fault. In any application where a malfunction of the actuator or its control system could lead to or allow damage, loss or injury, a risk analysis must be carried out, and where necessary, further measures taken to reduce the risk.- for example a failsafe brake in case of loss of actuator braking power.

Never attempt to connect or disconnect the actuator with power applied.

Dangerous voltages are present. Damage to equipment and injury to personnel can result. Refer to the following warnings on supply isolation and stored energy discharge time for more information.

WARNING Supply isolation



The AC supply or high voltage DC supply must be removed from the actuator using an approved isolation device or disconnect before any maintenance is performed except adjustments to the settings or parameters as specified in the manual.

WARNING Risk of Electric Shock. Allow 3 minutes for Discharge Time.



3-Minutes

The actuator contains capacitors that remain charged to a potentially lethal voltage for up to 3 minutes after the supply has been removed. Do not touch power wiring or terminals until this discharge time has expired.

WARNING If connected by plug and socket



A special hazard may exist where the actuator is incorporated into a system connected to the AC supply by a plug and socket. The pins of the plug are not generally isolated from the charge stored in the bus capacitor, so must be considered electrically “hot” until the discharge time has expired. It is the responsibility of the user to avoid any possibility of electric shock from the pins when they are accessible.

WARNING Grounding - High Leakage Current



The drive must be grounded by a conductor sufficient to carry all possible fault current in the event of a fault. This equipment has high earth leakage current. You must comply with local safety regulations with respect to minimum size and special installation requirements on the protective earth conductor for high leakage current equipment. The instructions for ground connections shown in this manual must be followed.

WARNING Fuses and Branch circuit protection



“The Integral solid state short circuit protection does not provide branch circuit protection. Branch circuit protection must be provided in accordance with the National Electrical Code and any additional local codes”, or equivalent. Fuses or over-current protection must be provided at the input in accordance with the instructions in the manual.

WARNING Hot Surface – Risk of Burn.



Exposed surfaces of the actuator may exceed 70 degrees C under normal operation and can take a long time to cool, resulting in a risk of burns when touched.

CSA Certified Product

The CVS Controls Electric Servo Pump is marked as shown after passing a rigorous set of design and testing criteria developed by CSA International (C22.2 No. 139). This label indicates that CSA certifies this product to be safe when installed according to the installation guidelines and used with the scope of the product specifications.

The conditions of acceptability required by CSA are:

- Drive input maximum continuous operating ratings:

Input Voltage (AC models): 12 – 24 Vdc, 18 Amps max		
Drive Model	Drive Description	Input Continuous Current (A rms)
TDM0750	75mm linear actuator	13

- Installation Requirements
 - Hazardous Location (Class I Division 2 Group A, B, C, D) installations – ½” rigid conduit with NPT connections and use UL approved copper only wires, 12 AWG, 300 Vac minimum rating, and 105° C minimum rating shall be used.
 - For other non-hazardous locations:
 - Use the above connection method, or
 - Cable with connector assemblies, or
 - Cables with cable glands are permitted.

For additional information on cable installations or part numbers contact CVS Controls Ltd.

- If a customer requires an additional +24 Vdc power supply to provide power then it must be a recognized or listed Class 2 Power Supply.
- Branch circuit protection must be provided. Reference the manual’s electrical installation section for fuse and circuit breaker options. Note: branch circuit protection must be located outside of the hazardous location environment,
- The full load ratings are at 25C ambient temperature.
- These conditions of acceptability only apply to units with a CSA mark on the product label.

General Specifications

CVS Controls Electric Servo Pump Overview

This manual applies to 75mm frame size with 12 – 24 Vdc input power. All of the required power components and motion processor are contained in the actuator housing.

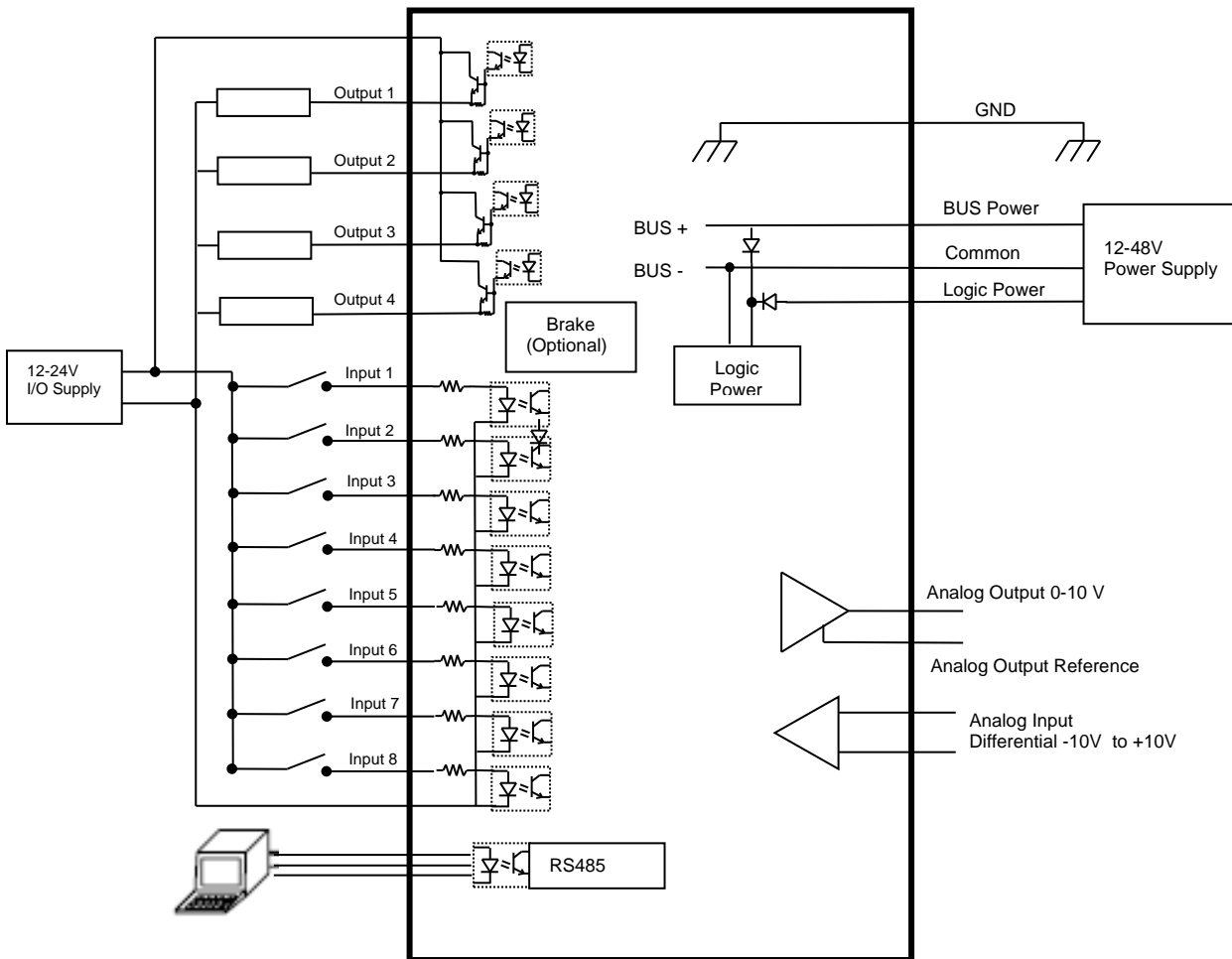

CVS Controls DC Electric Servo Pump Basic Block Diagram

Drive Specification for all CVS Controls Electric 12 -24 Volt Models

Drive Specifications	
Input Voltage, Bus and Logic	12 -24 Volts DC nominal
Control Logic supply (Optional)	12 -24 V dc +/- 10% - Class 2 or isolating source protected by 4A maximum fuse 0.5 A dc max load
I/O Power Supply	12 - 24 V dc nominal, 30V max 10V min
Enclosure Rating	Class 1, Div 2, Group A, B, C, and D-T4. IP65
Digital Inputs	8 – opto isolated, 12 to 30 V dc for ON state, 0 to 1V dc for OFF state, common return at “I/O Power Supply” “common” terminal Programmable functions
Digital Outputs	4 – opto isolated 100 mA continuous, short circuit protected, powered from “I/O Power Supply” with 1V maximum drop from supply voltage, programmable functions
Analog Input	0-10 Volts or +/- 10 Volts differential input, 12 bit resolution, programmable as position, velocity command currently used with the potentiometer to control pump rate.
Analog Output	0-10 Volts at up to 20 mA, 12 bit resolution, programmable function
Serial Interface	Optically isolated RS-485, Modbus RTU protocol, 38.4kbaud max
Commutation	Sinusoidal, 10kHz PWM
Position Resolution	0.001 revolution (with analog hall feedback)
Accuracy	+ / - 0.002 revolution (with analog hall feedback)
Environmental	Maximum Operating temperature range -40° C to 65° C

Ordering Configuration

MODEL	PLUNGER SIZE		PACKING		SEAT/O-RING	
CVS ECP DC	14	1/4"	B	Buna	B	Buna
	38	3/8"	F	Fluorosilicone	F	Fluorosilicone
	12	1/2"	V	Viton	V	Viton
			T	Teflon	T	Teflon
			K	Kalrez	K	Kalrez
					H	Hard

Example: CVS ECPDC-14-F-K

CVS Electric Chemical Pump DC, with 1/4" Plunger, Fluorosilicone Packing and Kalrez Seats

Electrical Installation

Introduction

All of the required power components and motion processor are contained in the actuator or drive housing. **NOTE: External means of approved power disconnect (switch) must be used prior to the pump DC input connections supplied by the customer.**

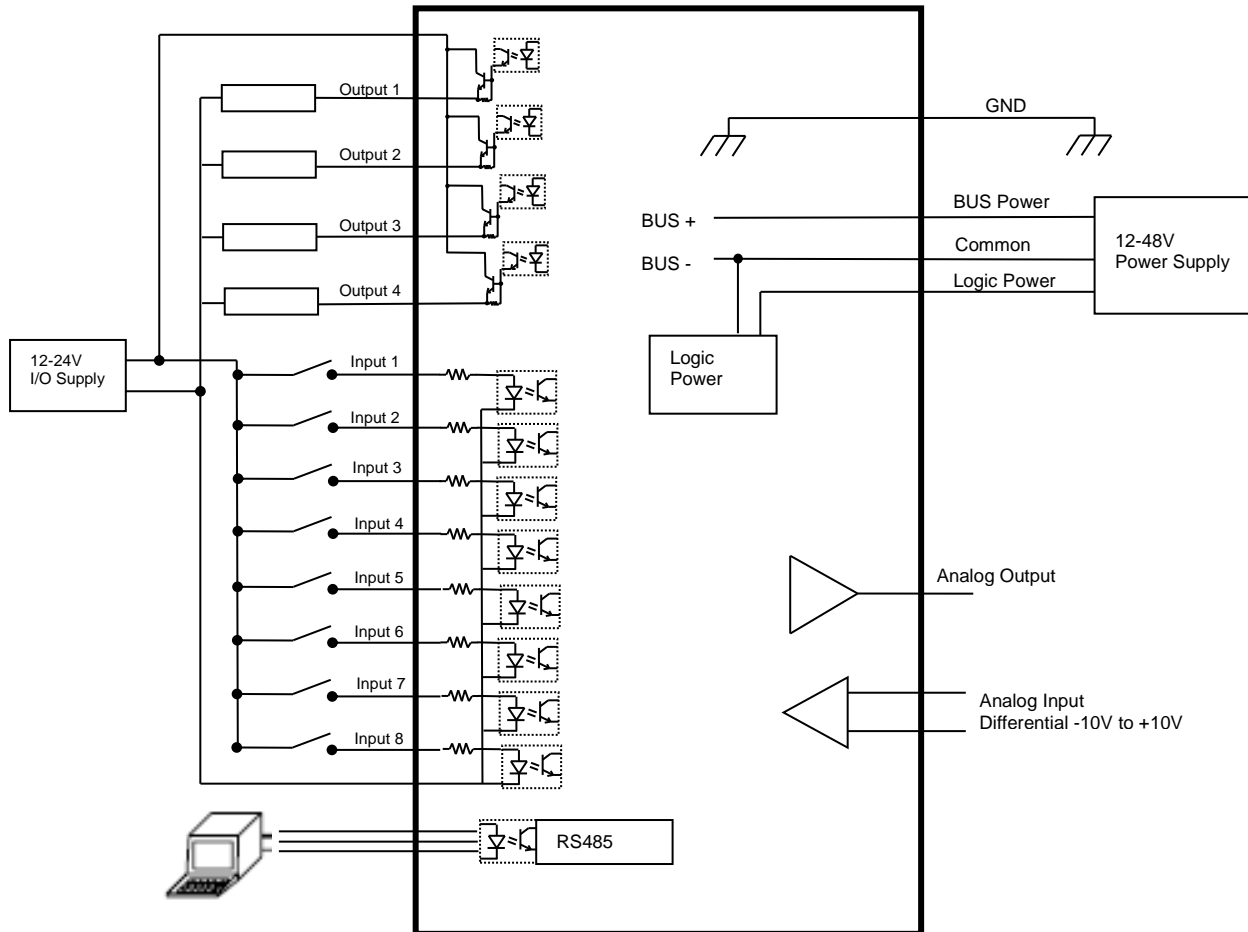

Main Power Supply Selection

The CVS Controls actuator requires DC power from a power supply or batteries. The actuator will operate on voltages from 12-48V DC nominal (12 -24 V DC for CSA certification). The continuous operating range is 10-53V DC. If the bus voltage rises above 85 V DC a High Bus Fault will occur and the drive will disable. The voltage threshold may be set lower through a user parameter where appropriate to protect a power supply from overvoltage during regen. The regen circuit will put a small charge back into the batteries. The power supply output current rating depends on the maximum actuator power required for the installation.

A 48V supply will allow the motor to deliver maximum rated speed, (specifications in Overview section) a 24V supply will allow the motor to deliver ½ the maximum rated speed, and a 12V Supply will allow the motor to deliver ¼ the maximum rated speed.

Power supply selection and connection is complicated by three factors associated with variable speed servo drives: high peak loads, power regeneration (regen) and switching frequency ripple current. Peak loads and regen will depend on the application. Ripple current can adversely affect some power supplies.

Note: This section does not pertain to an I/O or Holding Brake Power Supply. The I/O supplies have different limits and it is often inappropriate to use the same supply for all. See section on I/O Supply.

Power supply sizing for motion is based mainly on maximum mechanical power delivered to the load, which is force times velocity for linear or torque times angular velocity for rotary. The power supply has to provide this power which is rated voltage times maximum current plus about 20% to cover losses.

Either regulated or unregulated power supplies can be used for the bus and logic power. Different considerations pertain to each type, and each has advantages and disadvantages.

Unregulated AC/DC Power Supplies

CVS Controls Electric Pump operates well from a transformer isolated, unregulated DC power supply. This type of supply should be sized and connected such that the maximum output voltage under high-line and light-load conditions does not exceed the drive maximum voltage rating, $48V + 10\%$. For instance, when using the TTPS1048 power supply, if the line voltage ever rises above 120V AC, the supply should be connected for 132V AC operation to lower the output voltage by 9%. **(NOTE: CSA approval for 12 -24VDC only)**

Unregulated supplies have the advantage of being able to supply peak currents without overloading and will not trip on high voltage. Unregulated supplies have larger capacitance at the output, especially when compared to regulated switching supplies, providing greater energy recovery and storage during regen and tolerating high ripple current. See section on regen for more information on handling energy from regeneration. They have the disadvantage of output voltage droop as the current rises.

Unregulated supplies are usually rated only by continuous output current. For a very short time, not exceeding 1 second, they can typically output up to 200% of continuous current. Voltage droop may be significant above continuous voltage rating, which can reduce maximum speed. One sizing technique is to calculate the required average power over the worst 5 second interval in a machine cycle, add 20% and use that to determine continuous rated output power for an unregulated supply.

Regulated AC/DC Power Supplies

Most AC/DC power supplies available today are regulated switching power supplies. They are generally not designed to directly power brushless DC (BLDC) drives, but can do so with special consideration for the load that BLDC drives present to the supply and the overload characteristics of the power supply. These supplies provide very good output voltage regulation as well as high efficiency and smaller size and weight compared with unregulated linear supplies.

Due to over current protection, regulated supplies must generally be rated for the peak power required by the drive. Because the supplies limit output current, fuses between power supply and drive may not be able to interrupt fault current to the drive. The power supply must have output current foldback and / or output cycling on overload. Foldback is where the output current

limit is reduced more or less proportionally with the output voltage. Output cycling removes all output power on overload and waits a few seconds before attempting to restore power, limiting average power during faults. Fuses can still be very useful in isolating a fault when a large power supply is used to power several loads. Where conditions of use by an approval agency require fuse protection, the fuses must be installed even if they would not immediately clear a fault.

CAUTION



During deceleration of the load the energy generated from the motor and the load will increase the bus voltage and could possibly damage the output of a regulated power supply. If a regulated power supply is used for bus power, a blocking diode should be installed to protect the power supply. See Power Supply Wiring Diagrams section below

Regenerative energy due to deceleration will increase bus voltage and attempt to drive energy backward into a power supply. Regulated supplies may trip on overvoltage or recover slowly after being out of regulation causing a dip in output voltage at the end of a regen event. It may be necessary to use a blocking diode to allow the bus voltage at the drive to rise above normal supply voltage without any reverse current. CVS Controls offers a Power Distribution and Surge Filter assembly that includes a blocking diode, TDCESF1 (see Accessories section). See the section below on Handling Regen Energy

Another aspect of BLDC drive loads is that it tends to take pulses of current at twice internal switching frequency creating high ripple current. Some regulated supplies may not be able to tolerate high ripple current, depending on the final filter capacitors. The Power Distribution and Surge Filter assembly includes a small inductor that reduces ripple current. The blocking diode (if used) also reduces ripple current. Power wiring or power cables more than 30 ft (10 m) long provide enough impedance to reduce ripple current as well. Contact CVS Controls for additional information.

[Power from Battery Systems](#)

The CVS Controls DC pump is designed to be powered directly from 12V and 24V lead-acid batteries in vehicles. Regen energy and ripple current are not generally of concern with battery applications of this type. Battery systems generally will be able to supply peak power to the actuator. The average power may be a consideration in sizing the charging circuits for the battery system. Other battery powered applications are possible, but would require additional engineering considerations.

The product has not been tested for immunity to “load dump” conditions. An external voltage clamp designed specifically for load dump protection may be necessary on 24V systems.

[Handling Regen Energy – Internal Shunt Resistor and Regulator](#)

The DC pump has a built in controller and small internal shunt resistor that can handle up to 10 joules of energy at a time as long as average power does not exceed 8W. Though not high capacity, it is adequate to handle the inertia for many linear and geared applications and for some low-inertia rotary applications. The controller will turn off the shunt upon reaching either energy or power limits. If there is more regen energy, the bus voltage will rise, resulting in a high bus fault. To reset the fault simply disconnect the power wait 30 seconds and power up again.

Note: A poorly tuned system may have some oscillation that results in the bus voltage pumping up and down enough to turn on the shunt. This reduces the available capacity for handling

expected energy from deceleration. Likewise, if an overly aggressive move profile results in significant following error, there can be velocity overshoot followed by deceleration that causes unnecessary regen energy to reach the internal shunt resistor.

As shipped from the factory the internal regulator is set to a value to protect the pump from an overvoltage fault condition (85 V). this parameter will not require adjustment as long as the power supply can be back-driven to 85 V like most unregulated 48 V supplies, or can handle all the regen energy like most battery applications, or is isolated with a blocking diode. For other applications, the built in regulator can be adjusted to restrict bus voltage to a level that will protect the power supply from regen energy. Set the User Overvoltage Fault Limit Parameter found in the software on the System Set-up page / Limits tab to a value that the power supply can tolerate. The shunt regulator will operate at 90% of the User Overvoltage Fault Limit value. The drive will trip with a High Bus Voltage fault at the User Overvoltage Fault Limit value or at 85 V, whichever is lower. The default setting of 0 is a special case that means the factory parameter values of 85 V for trip and 76.5 V for shunt operation will be used.

In the example below a single 24 volt supply is used to power bus, logic and Field I/O, the logic power is derived internally from the bus power, the 24 volt regulated supply will keep the I/O voltage under the 30 volt limit. Notice there is no external diode, isolating the power supply from the Bus voltage. For this example, set the User Overvoltage Fault Limit to 33 V. The shunt regulator will attempt to limit the Bus Voltage to 30 volts (90% of 33 V) to protect the power supply from overvoltage faults & shutdowns and the I/O from overvoltage. If the regen energy is too large, the shunt regulator will turn off to protect itself and a high bus voltage fault will occur at 33 V, disabling the drive and protecting the power supply and I/O circuits.

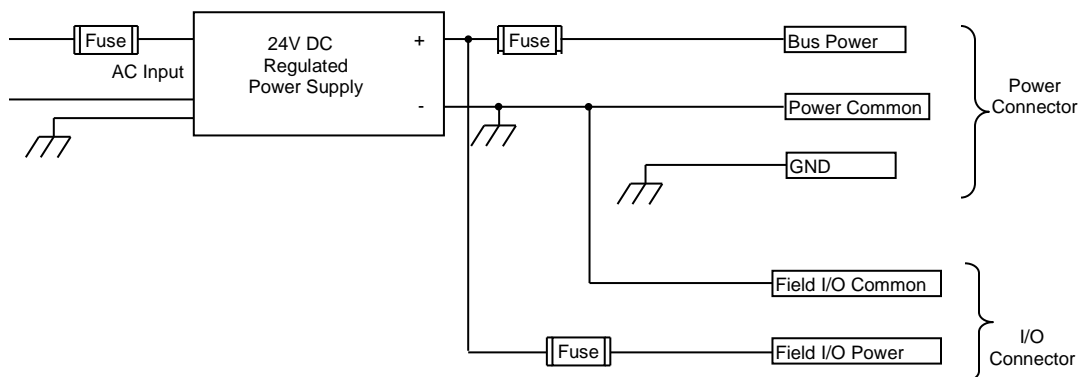

Unregulated supplies often have very large capacitors that can store regen energy if allowed to be back driven. This characteristic can be used in conjunction with the internal shunt resistor and regulator. The shunt operating point is set to the working voltage of the capacitors. Regen energy is stored in the capacitor until its voltage rises to the shunt operating point. Then the internal shunt accepts up to 10 J of additional energy.

Logic Power Supply

A logic power supply can be used to maintain the control and position information with bus power removed. This power supply is optional and requires about 2 watts of power. It is wired to the Logic Power terminal (+) and Power Common terminal (-). if it is not connected the logic power will come the bus power. Note that the main power and logic power share a return path. Logic Power can be the same wide range as the main power supply, 12 V, 24 V, or 48 V nominal, and can handle the regen voltages that appear on the main supply. A single supply

may be used for both with a relay contact in series with the main supply positive connection to remove bus power.

Power Supply Wiring Diagrams

WARNING All installations should provide a method of removing bus power during an emergency stop condition. The actuator enable function should not be relied on for this function when equipment or personnel safety is required. Disconnect only the + bus power, do not disconnect the - bus power.

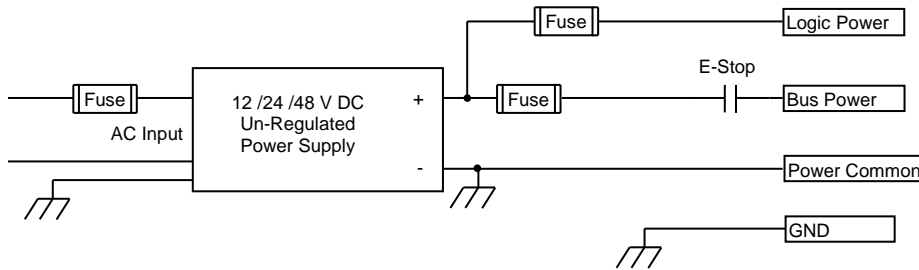

Un-Regulated Power Supply for Logic and Bus power

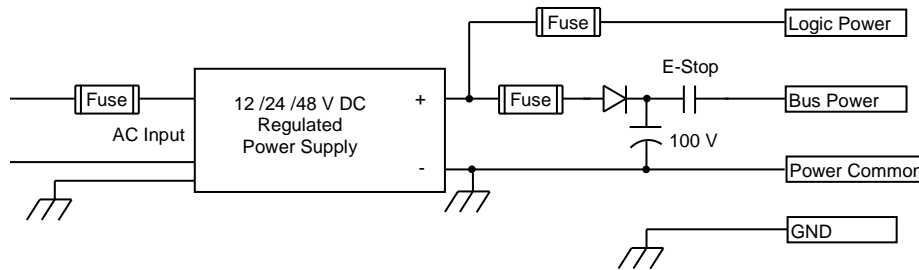

Regulated Power Supply for Logic and Bus power, with diode isolation and optional extra capacitance

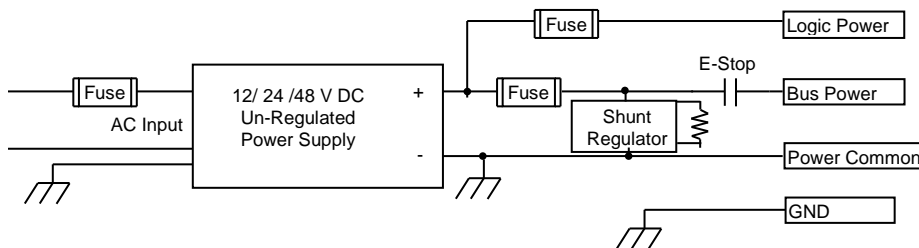

Un-Regulated Power Supply for Logic and Bus power, with a shunt regulator such as TTSR1

CAUTION Reversing polarity of the Bus Power (+) and Power Common (-) will cause a short circuit, which must be protected by the input fuse. See fusing below. If a fuse is not installed the drive could be permanently damaged.



Power Supply Wiring and Fusing

	Fuse	Wire
Bus Power	20 amp 125 V dc. Bussmann type ABC or similar.	12 gauge (4 mm ²)
Logic Power	2 amp 125 V dc. Bussmann type ABC or similar.	18 gauge (1,5 mm ²)

12 gauge wire is recommended for bus power to reduce voltage drop across the wire during peak power demands. If the application does not require high peak or continuous power, the wire gauge can be reduced, with a corresponding reduction in fuse rating.

WARNING If the wire gauge for bus power is reduced the fuse Amp rating must also be reduced in accordance with wire size, type and local regulations.



Shielding

For best EMC practices the power and I/O cable shields should be connected to the enclosure at the entry / exit point. This is most easily accomplished with EMC type cable glands.

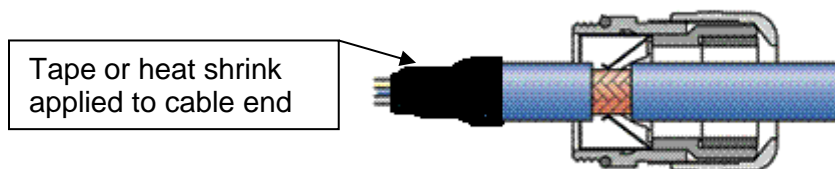

CAUTION

Always apply tape or heat shrink to the end of the shield to prevent strands of the braided shield from breaking off and shorting internal electronics

NPT Connections

The power and I/O wiring access holes are machined for ½ inch NPT fittings. Teflon tape or the equivalent must be used to seal the NPT thread connections as per location requirements.

Grounding

WARNING



The actuator and all power supply PEs and negative connections must be properly grounded using a single point grounding method.

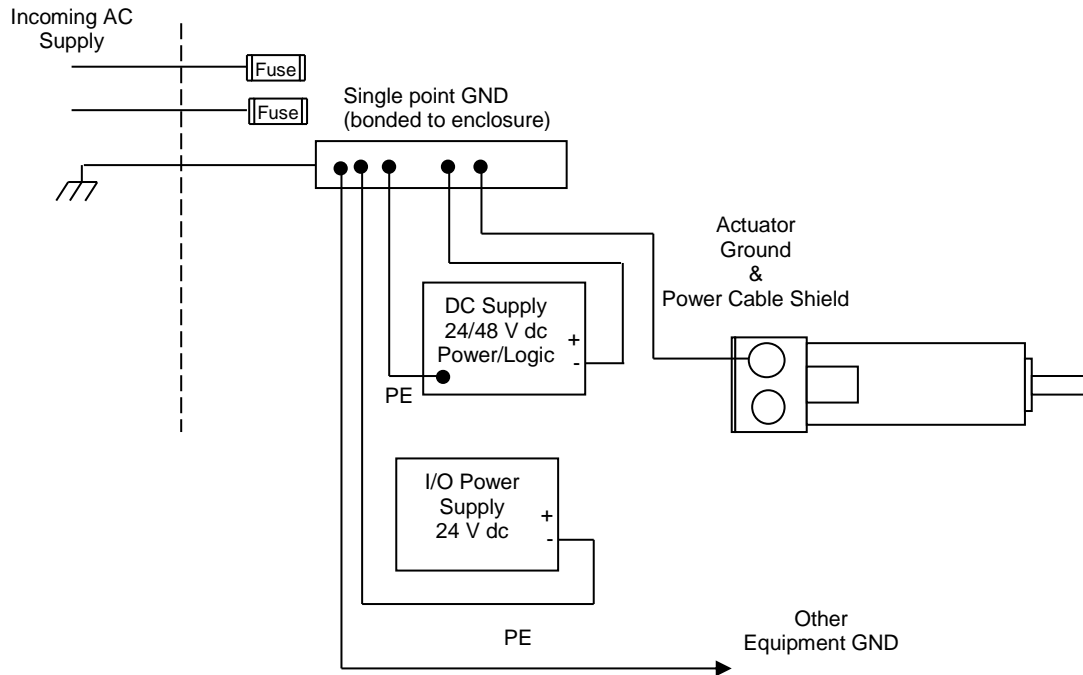

Grounding Diagram

Power Connections on Terminal board on CVS DC Pump

Signal	Terminal Label	Minimum Wire AWG.
Bus Power (+) 12-48 V dc	Bus +	12
Power Common (-)	COMMON	12
Logic Power (+) 12-48 V dc	LOGIC +	18
PE (GND)	PE	12

External means of approved power disconnect (switch) must be used prior to the pump DC input connections supplied by the customer.



Maintenance Procedures for Re-Greasing

Maintenance Procedure for Roller Screw Re-Greasing

Disassembly

Refer to the exploded view on the following page.

1.) Remove the actuator assembly from the machine by disconnecting the cables, main rod coupling clip and actuator mounting bolts on the fluid head yoke. The coupler and anti-rotate device can remain attached to the shaft for maintenance of the drive.



The end cap houses the servo drive and control. Extreme care should be taken when removing the tie rod nuts or tie rods so as not to twist or pull on the drive section of the actuator. Do not disconnect the wiring between the drive and the actuator.

2) Remove the screws holding the seal gland to the face plate. With the screws removed, pull the seal gland off. Pry spots are located on each side of the gland to aid in removal.

3.) When the seal gland is removed, the open end of the roller screw internally threaded cylinder (ITC) is visible. The roller screw can be removed by turning it counter clockwise and threading it out of the cylinder. It may be necessary to keep the roller screw cylinder from turning to remove the screw.

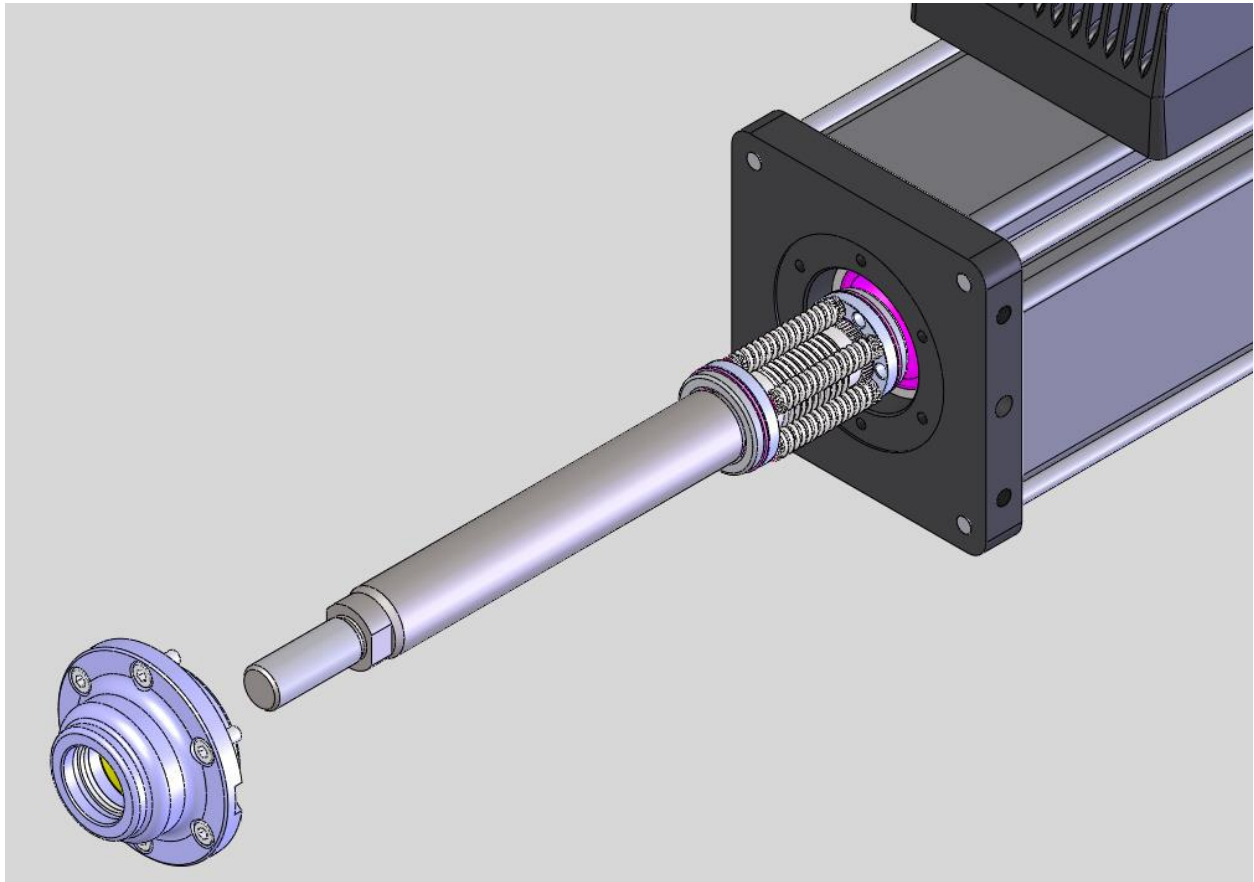

Lubrication Maintenance

Grease lubricated units will require periodic inspection and renewal of the roller screw grease. The table below shows the recommended grease renewal period.

Pump Speed Strokes Per Minute (SPM)	Recommended Grease Renewal Period (hours)	
	CASE TEMP 65°C (149°F)	
10	10,000	(14 months)
20	8,500	(12 months)
40	6,000	(8 months)
60	3,500	(5 months)



Rotary Speed Controller

Grease Renewal

The angular contact thrust bearings located in the front of the actuator, the roller screw cylinder, and the roller screw assembly are the components that require grease. They require a coating of grease. They do not need to be packed with grease. Excess grease

requires more torque from the motor when returned to operation, and does not improve the lubrication of the unit.

The CVS Controls servo actuators are shipped from the factory fully greased and ready for installation. CVS Controls recommends using Mobilith SHC 220, a high performance, extreme-pressure grease. The unique physical properties of the synthetic base oil provides outstanding protection against wear, rust, corrosion and high or low-temperature degradation. Mobilith SHC allows for very low starting and running torque values. Its operating range is -40 degrees C to 177 degrees C (-40 degrees F to 350 degrees F).

- 1.) Use a brush to work approximately 0.5 in³ of grease for every 3 inches of stroke length into the roller screw cylinder. Be sure to cover all of the threaded areas of the cylinder.
- 2.) Use a brush to work grease in to the roller screw assembly. Be sure to cover all the threaded surfaces of the screw assembly. This can be accomplished by applying grease to a few places on the roller screw assembly and rotating the components repeatedly in both directions to work the grease into the assembly.

Reassembly

- 1.) Rethread the roller screw into the internally threaded cylinder (ITC). It is a multiple start screw, and this is not always easy. **DO NOT FORCE THE ROLLER SCREW INTO THE CYLINDER.** It is best to have the actuator vertical with the open end of the roller screw cylinder facing up. Position the roller screw above the cylinder so that it is aligned axially with the ITC. Slowly turn the roller screw 1/4 to 1/2 a turn counterclockwise with it in contact with the ITC. This will help to align the threads on the roller screw with the threads in the ITC. Rotate the roller screw clockwise and it should begin to thread into the cylinder. If it does not turn freely, remove it and begin again. When threading the screw into the cylinder, it will roll freely into the actuator. When it reaches the portion of the cylinder that contains the motor magnets, the roller screw will be more difficult to turn because of the magnetic field of the magnets. **THIS IS NORMAL.** Continue to thread the roller screw into the cylinder. When it reaches the bottom, it will become difficult to turn and the motor and bearings will begin to rotate with it. The roller screw is now fully inserted into the cylinder.
- 2.) Place a small amount of seal lubricant on the inside surface of the seal/bushing assembly.
- 3.) Carefully slide the bushing/seal assembly over the actuator rod end. The seal is a tight fit on the rod end. Take care not to damage the seal on the threads of the extending rod. Standard T2M Series rods have a chamfer to provide a lead in for replacement of the seal and bushing. The mounting screws should have a low or medium strength thread locker added, such as Loctite 222MS. The mounting screws torque values are 27 in-lbs (2.25 lbf-ft, 3.05 N-m)
- 4.) Ensure the rod has been threaded all the way to the end. Reinstall the yoke and fluid head assembly. Slide the plunger into the coupler and insert the retaining clip.

Dimensions: CVS ECP-AC (Inches)

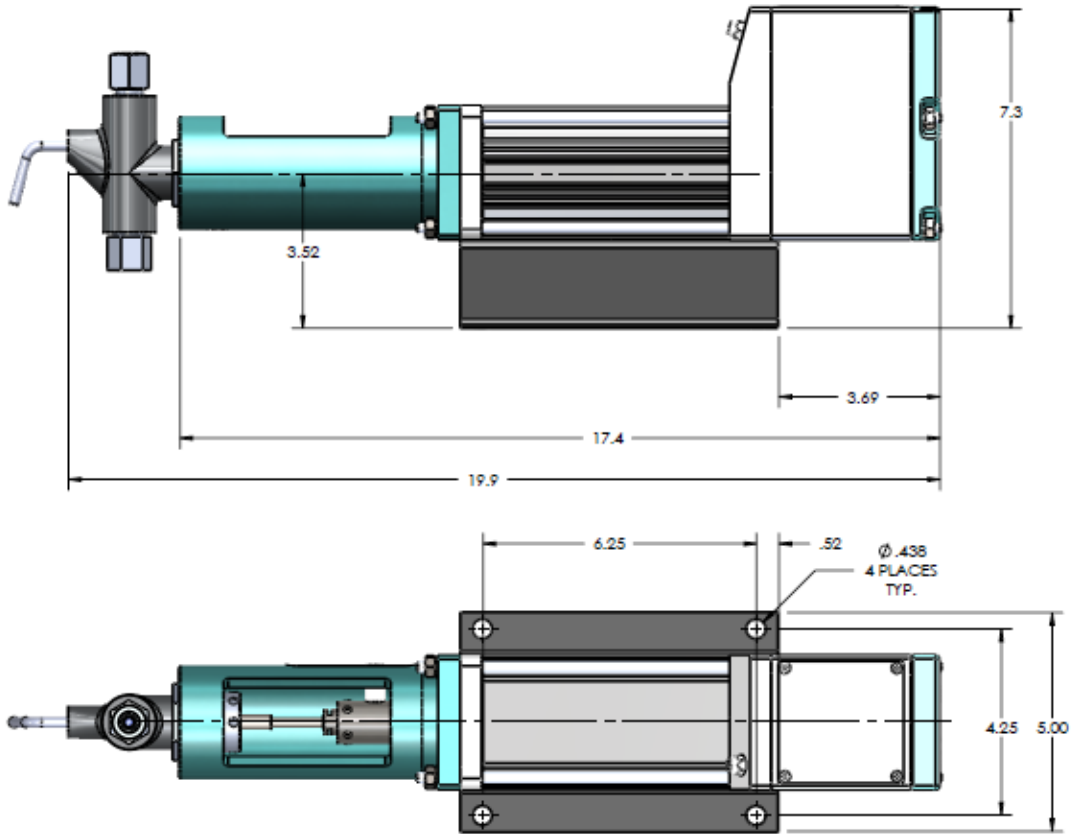

Electric Chemical Pump Volume Chart

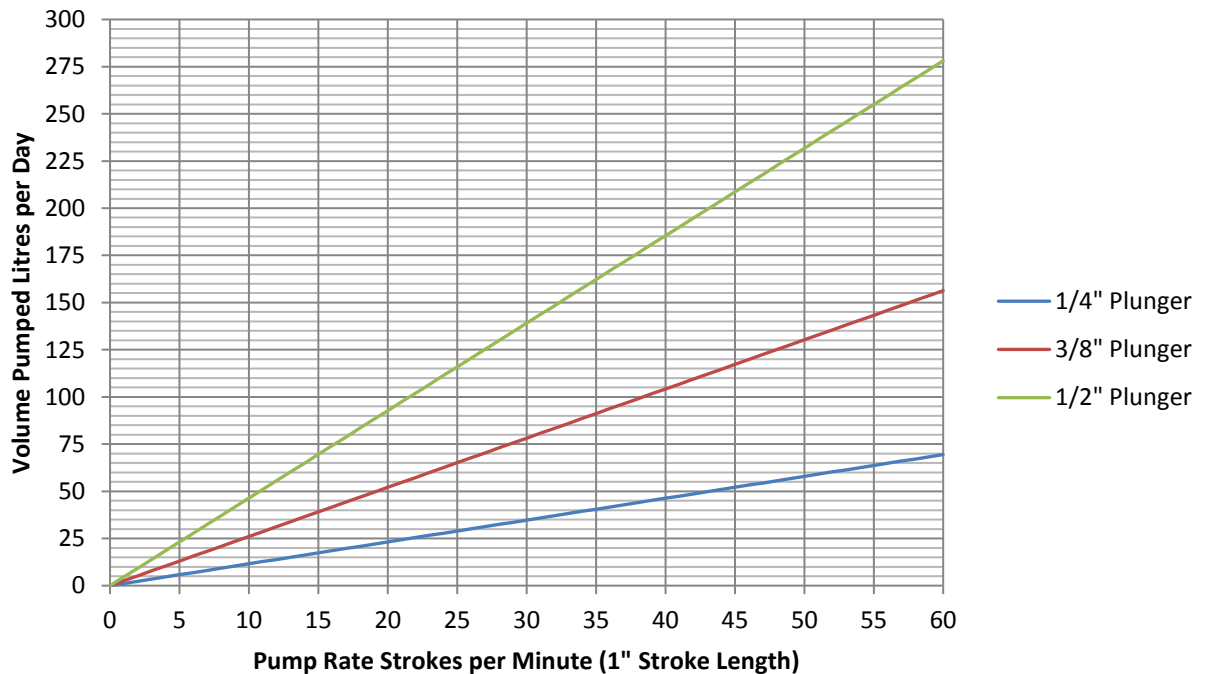

CVS Electric Chemical Pump- Injection Head Assembly

Pump Model Numbers			CVS Electric Chemical Pump – AC/DC					
Item	Description	Material	Ductile w/SST Trim	All SST Trim	Ductile w/SST Trim	All SST Trim	Ductile w/SST Trim	All SST Trim
	HEAD ASSY. NO.		CVS-LE-0166	CVS-LE-0755	CVS-LE-0203	CVS-LE-0756	CVS-LE-0496	CVS-LE-0732
1	Body		CVS-C-0275	CVS-C-0291	CVS-C-0276	CVS-C-0425	CVS-C-0272	CVS-C-0349
2*	Plunger	17-4PH	CVS-A-6269	CVS-A-6269	CVS-A-6270	CVS-A-6270	CVS-A-6271	CVS-A-6271
	Plunger, Cryo-Treated				CVS-A-1745/CT	CVS-A-1745/CT		
3	Plunger Packing Gland	303 SST	CVS-A-1463	CVS-A-1463	CVS-A-0957	CVS-A-0957	CVS-A-1219	CVS-A-1219
4*	Plunger Packing** (See table below for max. discharge press.)	Buna-N	CVS-A-1461	CVS-A-1461	CVS-A-1456	CVS-A-1456	CVS-A-0959	CVS-A-0959
		Hard	CVS-A-2295	CVS-A-2295	CVS-A-1875	CVS-A-1875	CVS-A-1874	CVS-A-1874
		Viton	CVS-A-4102	CVS-A-4102	CVS-A-4101	CVS-A-4101	CVS-A-4103	CVS-A-4103
		Teflon	CVS-A-1642	CVS-A-1642	CVS-A-1234	CVS-A-1234	CVS-A-1012	CVS-A-1012
		Flourosilicone	CVS-A-1461/FS	CVS-A-1461/FS	CVS-A-1456/FS	CVS-A-1456/FS	CVS-A-0959/FS	CVS-A-0959/FS
5*	O-Ring, Suction & discharge (included in items 9 & 14)	Buna-N Viton Flourosilicone	CVS-A-0479 CVS-A-2580 CVS-A-0479/FS	CVS-A-0479 CVS-A-2580 CVS-A-0479/FS	CVS-A-0479 CVS-A-2580 CVS-A-0479/FS	CVS-A-0479 CVS-A-2580 CVS-A-0479/FS	CVS-A-0479 CVS-A-2580 CVS-A-0479/FS	CVS-A-0479 CVS-A-2580 CVS-A-0479/FS
6	Top Bushing	302 SST	CVS-A-1496	CVS-A-1496	CVS-A-1496	CVS-A-1496	CVS-A-1496	CVS-A-1496
7*	Spring	316 SST	CVS-A-0077	CVS-A-0077	CVS-A-0077	CVS-A-0077	CVS-A-0077	CVS-A-0077
8*	3/8" SST Ball	316 SST	CVS-A-0054	CVS-A-0054	CVS-A-0054	CVS-A-0054	CVS-A-0054	CVS-A-0054
9*	Top Seat Assembly	303 SST	CVS-B-0737	CVS-B-0737	CVS-B-0737	CVS-B-0737	CVS-B-0737	CVS-B-0737
	Top Seat Assembly (Metal to Metal)		CVS-A-0806	CVS-A-0806	CVS-A-0806	CVS-A-0806	CVS-A-0806	CVS-A-0806
10*	1/4" SST Ball	316 SST	CVS-A-0126	CVS-A-0126	CVS-A-0126	CVS-A-0126	CVS-A-0126	CVS-A-0126
11	Priming Valve	303 SST	CVS-A-1497	CVS-A-1497	CVS-A-1497	CVS-A-1497	CVS-A-1497	CVS-A-1497
12	Plunger Pkg. Gland Nut	303 SST	CVS-A-4104	CVS-A-4104	CVS-A-4104	CVS-A-4104	CVS-A-4104	CVS-A-4104
13*	Suction Ball - 3/8"	316 SST	CVS-A-0054	CVS-A-0054	CVS-A-0054	CVS-A-0054	CVS-A-0054	CVS-A-0054
	Suction Ball - 1/2" (use with CVS-A-0771 metal to metal bottom seat only)		CVS-A-0053	CVS-A-0053	CVS-A-0053	CVS-A-0053	CVS-A-0053	CVS-A-0053
14*	Bottom Seat	303 SST	CVS-B-0736	CVS-B-0736	CVS-B-0736	CVS-B-0736	CVS-B-0736	CVS-B-0736
	Bottom Seat Metal to Metal (use with CVS-A-0053 1/2" ball only)		CVS-A-0771	CVS-A-0771	CVS-A-0771	CVS-A-0771	CVS-A-0771	CVS-A-0771
15	Locknut	Brass	CVS-A-0225	CVS-A-0225	CVS-A-0225	CVS-A-0225	CVS-A-0225	CVS-A-0225

Material	Pressure, PSIG		
	1/4"	3/8"	1/2"
Buna-N	1500	1500	1500
Hard	6000	6000	3500
Viton	3500	3500	3500
Teflon	1500	1500	1500
Flouro	1500	1500	1500

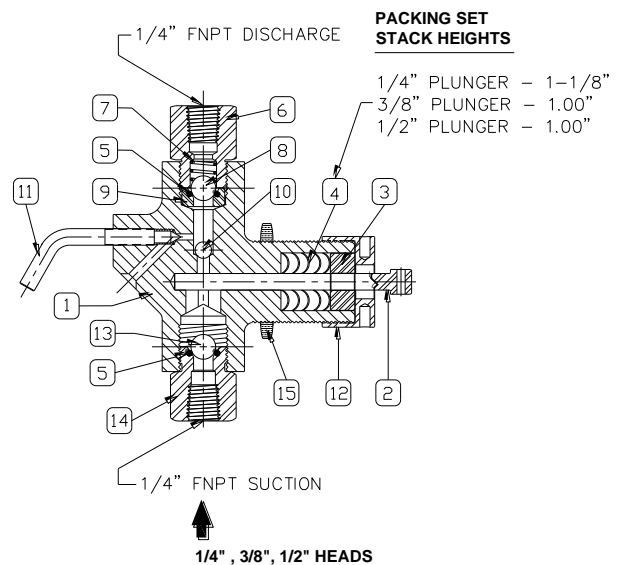

CVS

CONTROLS

Head Office

3900 101 Street
Edmonton, Alberta
T6E 0A5
Canada
Office: (780) 437-3055
Fax: (780) 436-5461

Calgary Sales Office

3516 114 Avenue SE
Calgary, Alberta
T2E 6Z3
Canada
Office: (403) 250-1416
Fax: (403) 291-9487

Website: www.cvs-controls.com

Email: info@cvs-controls.com