

CVS Series 18800 Hand Driven Centrifuge

The CVS Series 18800 Hand Driven Centrifuge delivers reliability, durability and rugged construction, making it ideal for field use.

The centrifuge has a smooth dual gear-driven system with a gear ration of 16:1 to assure efficient centrifugal force for Sediment and Water testing. The design of the gear ratio and throw of the crank produce a smooth, effortless motion with maximum speed and minimum effort.

The crank design provides ample clearance in all directions when the tube shields and samples are in motion. For rapid and secure attachment to surfaces, the lugs are serrated and the clamping screw comes furnished with a swivel-bearing washer and thumbscrew lever.

With ordinary care, the CVS Series 18800 Hand Driven Centrifuge will provide continuous service over a long period.

CVS 18801 Centrifuge, Hand Driven, 12.5 ml, 2-place Finger Type comes with 2 Finger Shields less tubes. Unit Wt = 6 Lbs, Shipping Wt = 7 Lbs

CVS 18811 Centrifuge, Hand Driven, 100 ml or 200%, 2-place Pear Type comes with 2 Pear Shields less tubes.
Unit Wt = 7 Lbs Shipping Wt = 8 Lbs

CVS 18821 Centrifuge, Hand Driven, 100 ml or 200%, 2-place Short Cone Type comes with 2 Short Cone Shields less tubes.
Unit Wt = 7 Lbs, Shipping Wt = 8 Lbs

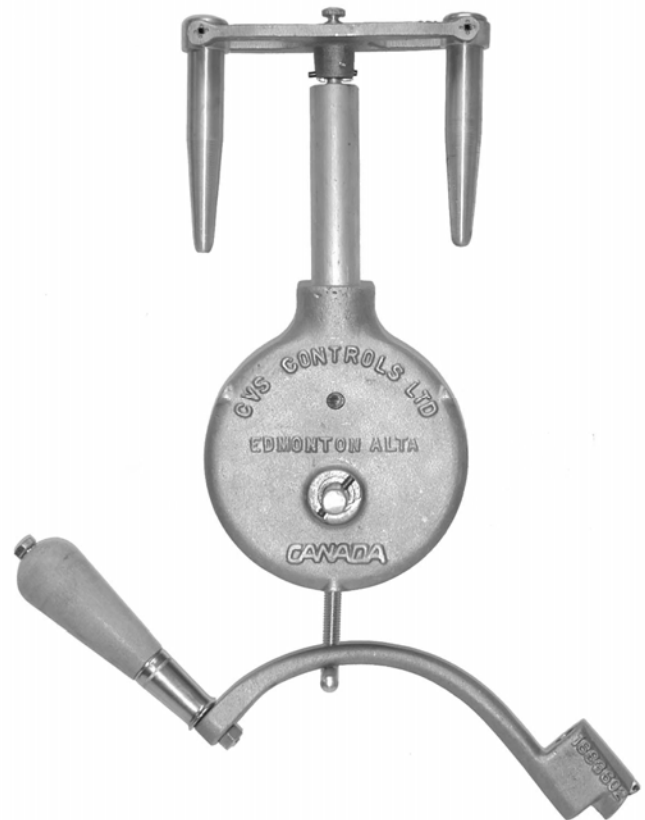

Figure 1: CVS 18800 Dual Gear Driven Hand Centrifuge

Parts List

Part Number	Description
CVS 18080	Shield for Pear Shaped Tubes
CVS 18081	Shield for Short Cone Tubes
CVS 18372	Shield for Finger Tubes
CVS 1883002	Body
CVS 1883608	Body Gasket
CVS 1883101	Crank Shaft
CVS 1883103	Main Gear
CVS 1883104	Gear Pin
CVS 1883105	Thrust Washer
CVS 1883106	Lock Screw (2 required)
CVS 1883107	Dual Gear
CVS 1883108	Dual Gear Shaft
CVS 1883109	Body Bearing
CVS 1883202	Cover
CVS 1883203	Cover Screw (4 required)
CVS 1883204	Cover Bearing
CVS 18833*	Clamp Foot Assembly
CVS 1883301	Thumb Screw
CVS 1883302	Handle Clamp
CVS 1883303	Clamp Handle Pin
CVS 1883304	Foot Clamp

Part Number	Description
CVS 18835*	Drive Shaft Assembly
CVS 1883401	Drive Shaft
CVS 1883402	Lower Bearing
CVS 1883403	Pinion Gear
CVS 1883404	Nut, Shaft
CVS 1883501	Housing
CVS 1883502	Upper Bushing
CVS 1883503	Retaining Ring
CVS 1883504	Head Pin
CVS 1883505	Head Nut
CVS 18836*	Crank Assembly
CVS 1883602	Crank
CVS 1883604	Handle
CVS 1883605	Handle Bolt
CVS 1883606	Handle Nut
CVS 1883607	Clutch Pin
CVS 18861	2-Place Head for Finger Tubes
CVS 18872	2-Place Head for Pear Tubes
CVS 18873	2-Place Head for Short Cone Tube
CVS 1883506	Roll Pin

* These assemblies may be purchased complete.

Parts not shown:
 (See Parts List for description)

- CVS 18080
- CVS 18081
- CVS 1883203
- CVS 18872
- CVS 18873

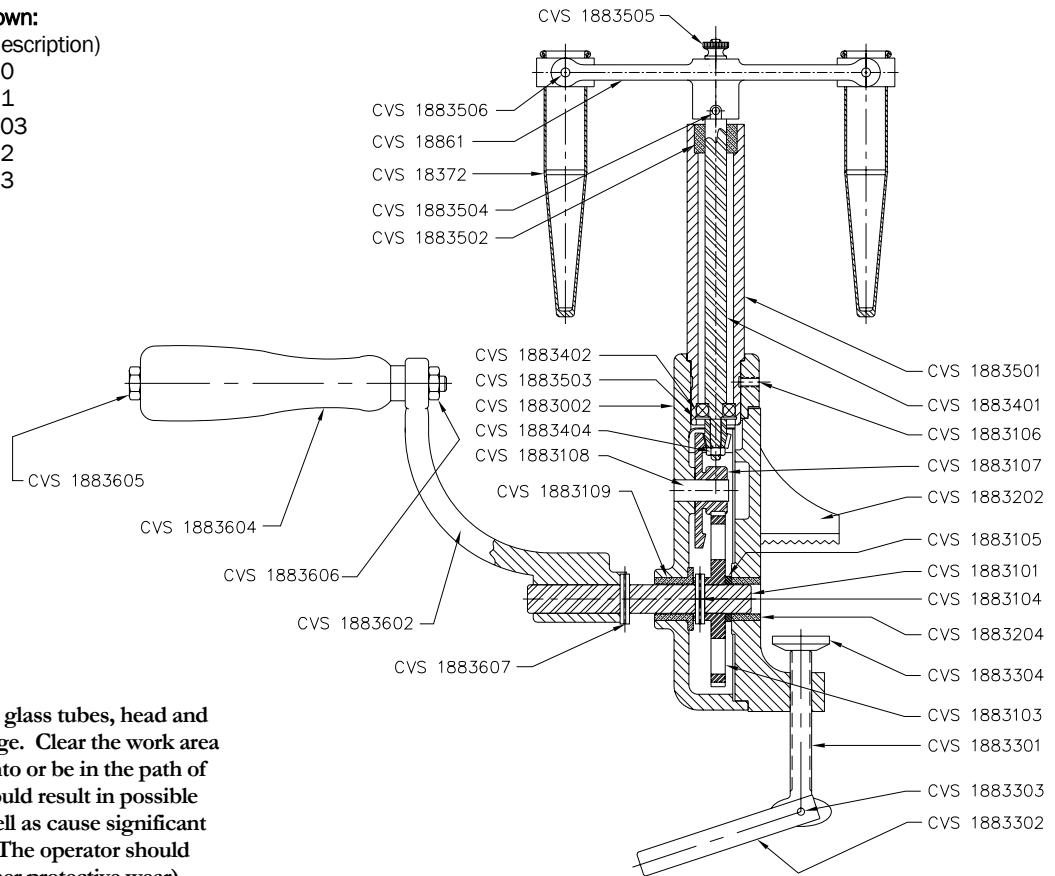

Before operation, examine glass tubes, head and machine for wear or damage. Clear the work area of articles that might fall into or be in the path of the whirling head. This could result in possible injury to the operator as well as cause significant damage to the machine. (The operator should wear safety glasses and other protective wear).